

276 00

85054709

OFFICIAL RECORDS *
BOOK 2740
PAGE 1083

PREPARED BY:
R. CRAIG HARRISON, ESQ.
LYONS & BEAUDRY, P.A.
1605 Main St., Suite 1111
Sarasota, FL 34236

185 ✓

DECLARATION OF CONDOMINIUM OF
ASHTON LAKES NO. 9, a Condominium

This Declaration of Condominium made this 1ST day of May, 1995, by ASHTON LAKES DEVELOPMENT II, INC., a Florida corporation, hereinafter referred to as "Developer", for itself, its grantees, designees, successors, substitutes and assigns, now witness:

The Developer makes the following declarations:

ARTICLE 1.
Purpose

1.1) The purpose of this Declaration is to submit, and the Developer hereby submits, the fee simple title to the land described in Exhibit "1" attached to this instrument, all easements appurtenant thereto, and the improvements now and hereafter constructed thereon to the Condominium form of ownership and use in the manner provided by Chapter 718, Florida Statutes, as most recently amended (herein called the "Condominium Act").

ARTICLE 2.
Identification

2.1) Name and Address. The name by which this Condominium property is to be identified is ASHTON LAKES NO. 9, a Condominium, and its address is 2951 Clark Road, Sarasota, County of Sarasota, Florida 34231.

2.2) The Land. The legal description of the lands owned by the Owner in fee simple, which are hereby submitted to the condominium form of ownership at this time, are the lands lying in Sarasota County, Florida, more particularly described in Exhibit "1", attached hereto and made a part hereof (which lands are herein called the "Lands"), together with and subject to the easements, encumbrances, restrictions and other matters set forth therein or hereinafter described in this Declaration or any of the Exhibits hereto.

ARTICLE 3.
Definitions

3.1) Assessment. Assessment means a share of the funds required for the payment of the common expenses, which from time to time is assessed against the Unit Owner.

3.2) Association. Association means ASHTON LAKES NO. 9 CONDOMINIUM ASSOCIATION, INC., a non-profit Florida corporation, which is responsible for the operation and management of the Condominium, and its successors and assigns.

3.3) Community Association. Community Association means ASHTON LAKES COMMUNITY ASSOCIATION, INC., which is responsible for the operation, maintenance, repair, and improvement of the ASHTON LAKES Community.

3.4) ASHTON LAKES Community Facilities. The ASHTON LAKES Community Facilities shall include the entryway, roads, streets, parking not assigned, lawns, gardens, shrubs, trees, water and sewer mains and related facilities, utility services not owned by others, ditches, lakes and all other drainage facilities, the administration building, clubhouse, pool, shuffleboard courts, pedestrian walkway, tennis courts, picnic area, television service, and any other utilities which are not metered to the individual Units.

3.5) ASHTON LAKES Residences. The ASHTON LAKES Residences shall include all of the various condominiums and other forms of association and ownership of residential units located within the ASHTON LAKES Community.

3.6) The ASHTON LAKES Community. The ASHTON LAKES Community shall include the real estate with improvements described on Exhibit "A", a part of the Declaration of Condominium of ASHTON LAKES, a Condominium, recorded in Official Record Book 1708, pages 116-212, both inclusive, and the plat of ASHTON LAKES, a Condominium, recorded separately in Condominium Book 23, pages 4, 4A thru 4N, both inclusive, (whether submitted to condominium ownership or not by the above described Declaration of Condominium) except that the area labeled "Recreation Area" which appears on sheet 4 of Exhibit "A", which is also recorded in Official Record Book 1708, page 170, and Condominium Book 23, page 4C, and is illustrated by the drawing on sheet 12 of Exhibit "A" which is also Official Record Book 1708, page 178, and Condominium Book 23, page 4K, is not included.

3.7) Board of Administration. Board of Administration means the Board of Administration of the Association who are responsible for the administration of the Association.

3.8) Building. Building means the structure on the Condominium property in which the Units are located, regardless of the number of such structures.

3.9) Bylaws. Bylaws means Bylaws of the Association mentioned above as they exist from time to time.

3.10) Common Elements. Common elements means the portions of the Condominium property not included in the Units as more particularly identified at Paragraph 4.10) hereinafter and shall include: (a) the portions of the Condominium property not included in the Units; (b) other items as stated in the Condominium Act; (c) easements through Units for conduits, ducts, plumbing, wiring and other facilities for the furnishing of utility and other services to Units in the common elements; and (d) an easement of support in every portion of a Unit which contributes to the support of the building.

3.11) Common Expenses. Common expenses mean all the expenses and assessments properly incurred by the Association for the Condominium and all expenses for which unit owners are liable to the Association and include, but are not limited to, the following:

(a) Costs and expenses. Costs and expenses of maintenance, operation, repair or replacement of the common elements (including limited common elements, except as otherwise hereinafter declared to be obligations of one or more particular units), and of the portions of Units to be maintained by the Association, including but not limited to:

(i) Fire, other casualty, flood, liability, Workmen's Compensation and other insurance as provided herein.

(ii) Administrative costs of the Association, including professional fees and expenses.

(iii) Cost of water service, sewage service, garbage collection and trash removal, pest control, cable T.V., or at the election of developer master antenna or satellite dish, or similar technology (but only the cost of two (2) outlets per Unit), and of other utilities which are not metered to the individual Condominium Units.

(iv) Damages to the Condominium property in excess of insurance coverage.

(v) Expenses of management of the Condominium.

(vi) All other costs and expenses that may be duly incurred by the Association through its Board of Administration from time to time in operating, protecting, managing and conserving the Condominium property and in carrying out its duties and responsibilities as provided by the Condominium Act, this Declaration or the Bylaws.

(b) Expenses of ASHTON LAKES COMMUNITY ASSOCIATION. The costs and expenses of maintenance, operation, repair, or replacement of the lands and improvements of the ASHTON LAKES COMMUNITY ASSOCIATION, which shall include the entryway, roads, streets, parking not assigned, lawns, gardens, shrubs, trees, water and sewer mains and related facilities, utility services not owned by others, ditches, lakes and all other drainage facilities, the administration building, clubhouse, pool, tennis courts and picnic area, television service, and any other utilities which are not metered to the individual Units. This cost will be due to the ASHTON LAKES COMMUNITY ASSOCIATION from each of the owners of single-family residential units located throughout the ASHTON LAKES Residences. The expenses of ASHTON LAKES COMMUNITY ASSOCIATION property will be collected by each condominium and community association located within the ASHTON LAKES Residences from the single-family units located within that particular Condominium or community association as part of the periodic maintenance fee of each individual Condominium Association or community organization.

The expenses of ASHTON LAKES COMMUNITY ASSOCIATION, which will be included in periodic assessments, may include:

(i) Fire, other casualty, flood, liability, Workmen's Compensation and other insurance as provided herein.

(ii) Administrative costs of ASHTON LAKES Community Association, including professional fees and expenses.

(iii) Cost of water service, sewage service, garbage collection, trash removal, pest control, cable T.V., and of other utilities which are not metered to individual Units.

(iv) Labor, materials and supplies used in conjunction with the operation, replacement, repair and maintenance of common facilities which may include but not be limited to the swimming pool, clubhouse, tennis courts and other part recreational facilities and any limited common elements, except as otherwise hereinafter declared to be obligations of one or more particular Units.

(v) The cost of such additional land, improvements and personal property as may be purchased and added to the ASHTON LAKES Community by the Association through action of the Board of Administration.

(vi) Damages to the Community property in excess of insurance coverage.

(vii) Expenses of management of ASHTON LAKES Community Association which may include:

(1) Salary of a manager, if any, his assistants and agents,

(2) Management fees payable to an outside management company, if any, and

(3) Other expenses incurred in the management of the community property.

(viii) All outlays, costs and expenses, if any, incurred by ASHTON LAKES Community Association in connection with the purchase, rental, operation, maintenance and repair of a Unit to house a resident manager, including without limitation, debt service, utilities, taxes and the share of common expenses otherwise allocable to such Unit.

(ix) All other costs and expenses that may be duly incurred by the ASHTON LAKES Community Association through its Board of Administration from time to time in operating, protecting, managing and conserving the property of ASHTON LAKES Facilities

and in carrying out its duties and responsibilities.

(x) The cost and expense of acquiring, managing, operating, maintaining, repairing and replacing all land, improvements and personal property owned or leased by ASHTON LAKES Community Association and such additional land, improvements and personal property as may be purchased by said Association.

(c) Expenses declared common expenses by provisions of the Condominium Act, this Declaration or the Bylaws.

(d) Any valid charge against the Condominium property as a whole.

3.12) Not Common Elements and Not Common Expense. A Unit shall include the heating and air conditioning equipment serving the particular Unit (whether such equipment is located inside or outside the Unit), garage doors and garage door openers. The cost and expense of maintaining, repairing and replacing all heating and air-conditioning equipment serving a particular Unit, garage doors and garage door openers are not a common expense but are the individual expense of the Owner of the Unit being served by such equipment. The cost and expense of maintaining, repairing or replacing all lines and conduits running from heating and air-conditioning equipment located outside a Unit to the Unit being served by such equipment shall be a common expense.

3.13) Common Surplus. Common surplus means the excess of all receipts of the Association, including but not limited to, assessments, rents, profits and revenues on account of the common elements, over the amount of common expenses.

3.14) Condominium. Condominium means all of the Condominium property as a whole when the context so permits, as well as the meaning stated in the Condominium Act.

3.15) Condominium Parcel. Condominium Parcel means a Unit together with the undivided share in the common elements which is appurtenant to the Unit. All appurtenances to a Unit pass with conveyance of the Unit without specific description or reference.

3.16) Condominium Property. Condominium Property means the land, leaseholds and personal properties that are subjected to condominium ownership under this Declaration, whether or not contiguous, and all improvements thereon and all easements and rights appurtenant thereto intended for use in connection with the Condominium.

3.17) Definitions. The terms used in this Declaration and its Exhibits shall have the meanings stated in the Condominium Act and as herein provided, unless the context otherwise requires.

3.18) Declaration. Declaration or Declaration of Condominium means this instrument and all exhibits hereto as it may be amended from time to time hereafter as provided for within this instrument.

3.19) Developer. Developer means Ashton Lakes Development II, Inc., a Florida corporation, its grantees, designees, successors, substitutes and assigns.

3.20) Improvements. Improvements mean all structures, or any portion thereof, and artificial changes to the natural environment (exclusive of landscaping), located on the Condominium property.

3.21) Institutional Lender or Institutional First Mortgagee. Institutional lender or institutional first mortgagee shall be construed to include but not be limited to banks, savings and loan associations, insurance companies, Massachusetts business trusts, real estate investment trusts, mortgage bankers, mortgage brokers and agencies of the U.S. Government, FNMA and FHLMC, their respective successors and/or assigns, the construction lender(s) for the Condominium and the Developer holding a mortgage on a unit or units.

3.22) Lands. Lands shall mean the real property being submitted to

condominium ownership by this Declaration as ASHTON LAKES NO. 9, a Condominium, and which is more particularly set forth in Exhibit "1".

3.23) Limited Common Elements. Limited common elements shall mean those common elements, if any, which are reserved for the exclusive use of a certain Unit or Units to the exclusion of other Units as specified herein.

3.24) Occupant. Occupant shall mean a person or persons in lawful possession of a Unit other than the owner or owners thereof.

3.25) Operation. Operation or Operation of the Condominium means and includes the administration and management of the Condominium property.

3.26) Singular, Plural, Gender. Whenever the context so permits, the use of the plural shall include the singular, the singular the plural, and the use of any gender shall be deemed to include all genders.

3.27) The Condominium. The Condominium or this Condominium, as and herein used from time to time, shall mean the apartment complex subjected hereby to condominium ownership, known as ASHTON LAKES NO. 9, a Condominium.

3.28) Unit. Unit means a part of the Condominium property which is to be subject to exclusive ownership, which has been improved to provide a single-family dwelling unit ready for occupancy, together with all appurtenances thereto.

3.29) Unit Owner. Unit Owner or Owner of a Unit means the owner of a Condominium parcel.

3.30) Utility Services. As used in the Condominium Act and as construed with reference to this Condominium, and as used in the Declaration, Articles and Bylaws, utility services shall include, but not be limited to, electric power, telephone, gas, hot and cold water, heating, refrigeration, air-conditioning, cable TV, master antenna and/or satellite dish, and garbage, trash and sewage disposal.

ARTICLE 4
Development Plan

4.1) Development Plan. The Condominium is described and established as follows:

4.2) (a) Description of ASHTON LAKES NO. 9, a Condominium. This Condominium is located in the general area designated for Building 2 in the plat of ASHTON LAKES Condominium recorded in Condominium Book 23, pages 4, 4A through 4N, both inclusive, and more precisely shown on Exhibit "2" attached to this Declaration of Condominium and the condominium shall consist of one (1) building, containing a total of twenty-four (24) units.

(b) Each unit shall have a number designation and a mailing address on Ashton Way, which is the same and is set forth below. The numbering shall commence at the left side of the building when standing on the street facing the building.

ASHTON LAKES NO. 9, a Condominium

Building 2:

Third Floor	5633	5635	5637	5639	5641	5643	5645	5647
Second Floor	5617	5619	5621	5623	5625	5627	5629	5631
First Floor	5601	5603	5605	5607	5609	5611	5613	5615

(c) The legal description of a Unit in ASHTON LAKES NO. 9, a Condominium, shall be:

Unit _____, ASHTON LAKES NO. 9, a Condominium, according to the Declaration of Condominium recorded in Official Record Book _____, page _____, both inclusive, and Plat of Condominium recorded in Condominium Book __, pages _____ through _____, inclusive, of the Public Records of Sarasota County, Florida.

(d) Share of the Common Elements and Common Surplus. Each Condominium unit owner in ASHTON LAKES NO. 9, a Condominium, will own one-twenty-fourth (1/24th) of the common elements and the common surplus, and will share and be responsible for one-twenty-fourth (1/24th) of the common expenses of this Condominium.

(e) Recreational Facilities Not Common Elements. The recreational facilities and other property described below are not common elements but are owned and operated by ASHTON LAKES COMMUNITY ASSOCIATION, INC. for the use and benefit of all of the owners of ASHTON LAKES Residences, and the owners of units in adjacent lands. These facilities shall include:

(1) Sales Office/Association Administration Building. A temporary sales office and construction office of approximately 1,150 ± square feet, wood frame with tile roof containing a men's and women's bathroom, kitchenette with capacity to reasonably hold ten persons at one time. The Developer has reserved the right to use the office as a construction and sales office for the sale and rental of units within the ASHTON LAKES Residences and adjoining properties.

(2) Recreation Building and Swimming Pool. The recreation clubhouse and swimming pool are in the location depicted on the Plat of ASHTON LAKES, a Condominium recorded in Condominium Book 23, pages 4, 4A through 4N, of the Public Records of Sarasota County, Florida. The recreation building and pool have been constructed. The building is approximately 1,800± square feet, single level, contains a kitchen of approximately 200± square feet with standard commercial appliances, stucco exterior upon timber frame with tile roof, which contains a women's bathroom with four toilets (one of which shall be for handicap persons) and men's bathroom containing two urinals and three toilets (one of which shall be for handicap persons). The recreation building has a capacity of holding approximately 60 persons or as may be required by governmental authorities, within the common meeting room.

The swimming pool is equipped with an approved commercial filter system, one ladder, a hook and safety line with a float, and water testing kit. There is pool side furniture and other pool equipment which was provided by the Developer at a cost of at least \$1,000.00. The swimming pool has a range of depth from 1 foot to 6 feet±, with an approximate size of 35 feet by 65 feet, approximate surface area of 2,275 square feet. The pool does not have a diving board, but is surrounded by a cement deck of approximately 1,000 square feet. The recreation clubhouse and swimming pool have been constructed and are situated in the approximate location as shown on Exhibit "A" attached to the Declaration of Condominium of ASHTON LAKES, a Condominium, with recording information as above.

(3) Shuffleboard Courts. There are two (2) hard surfaced shuffleboard courts adjoining one another in combination. They shall comprise an approximate area of 52' by 20'. They shall be unlighted. Appropriate equipment shall be provided to accommodate two (2) people in play at one time on each court.

(4) Picnic and Tennis Court Area. There are two hard-surface, unlighted tennis courts, approximately 120 feet by 105 feet each, equipped with four posts, two nets, and appropriate fencing which will accommodate four people in play per court at any one time. There is seating, shade, two picnic areas, each with one table, two benches, and a charcoal grill.

(5) Drainage and Retention Lake Areas. Existing and additional lakes, ditches and drainage facilities have been excavated to provide drainage and serve as storm water retention areas and to provide a pleasant water appearance. Alteration of the shore line and/or excavation or filling of any existing lake and excavation to establish new lakes, ditches and drainage facilities is granted to the Developer and is subject to a combination of County, State and/or Federal permits issued by the appropriate departments or agencies for each.

(6) Pedestrian Walkway. The Developer has constructed a wooden walkway as a pedestrian access from the ASHTON LAKES Community to the adjoining Merchants Point Shopping Center.

(7) Ingress and Egress, and Utilities. The other areas which make up the ASHTON LAKES Community Facilities shall include the entryway, roads, streets, parking not assigned, lawns, gardens, shrubs, trees, water and sewer mains and related

facilities, utility services not owned by others, ditches, lakes and all other drainage facilities, the administration building, clubhouse, pool, tennis courts and picnic area, and any other utilities which are not metered to the individual Units.

4.3) Easements. Each of the following easements are hereby granted, reserved or otherwise created in favor of the Developer, its grantees, successors and assigns for the benefit of the units in ASHTON LAKES Residences and adjoining lands of Developer or its assigns (and in favor of other public or franchised utility companies, but as to such utility companies only where expressly specified) and are covenants running with the Condominium, and notwithstanding any of the other provisions of this Declaration, may not be amended or revoked and shall survive the termination of the Condominium and the exclusion of any of the lands of the Condominium from the Condominium, for the benefit of the ASHTON LAKES COMMUNITY ASSOCIATION, and the owners and grantees of units in ASHTON LAKES NO. 9, a Condominium, and the various condominiums and other associations and forms of ownership, constructed or to be constructed, upon the real property described on Exhibit "A" attached to the Declaration of Condominium of ASHTON LAKES, a Condominium, recorded in Official Record Book 1708, pages 116-212, both inclusive, which is also Condominium Book 23, pages 4, 4A through 4N, both inclusive, of the Public Records of Sarasota County, Florida. In addition, the foregoing easements are for the benefit of owners of the improvements to be located on the real property designated Recreation Area on Sheet 4 of Exhibit "A" attached to the Declaration of Condominium of Ashton Lakes, which is also recorded in Official Record Book 1708, page 170, and Condominium Book 23, page 4C, and illustrated by drawing on Sheet 12 of Exhibit "A" of the Declaration of Condominium, which is recorded in Official Record Book 1708, pages 178, and Condominium Book 23, pages 4K, all in the Public Records of Sarasota County, Florida, but such Owners shall not be subject to the easements.

(a) Utilities and Drainage. Drainage easements and easements for all water, sewer, electrical, telephone, cable TV, master antenna, satellite dish or other TV service, and other utility lines, mains, and facilities and drainage ditches, lines and structures, lakes and other drainage facilities previously, now or hereafter providing service to the Condominium and all other condominiums, associations, and other types of ownership within the ASHTON LAKES Residences and adjacent lands,, the installation, repair, maintenance and replacement thereof and as may subsequently be required for utility services in order to adequately serve the Condominium and all other condominiums, associations, and other types of ownership within ASHTON LAKES Residences and adjacent lands, provided, however, easements through a Unit shall only be according to the plans and specifications for the building containing the Unit or as the building is actually constructed, unless approved in writing by the Unit Owner. The foregoing utility easements are and shall also be in favor of all utility companies servicing the Condominium.

(b) Pedestrian and Vehicular Traffic. For pedestrian traffic over, through and across sidewalks, bicycle paths, other paths, walks, lanes, roads and streets as the same may from time to time exist upon the common elements of the Condominium and the other condominiums within Ashton Lakes Residences and adjacent lands, and the lands of ASHTON LAKES COMMUNITY ASSOCIATION; and for the vehicular traffic over, through and across such portion of the common elements of the Condominium and the other condominiums within Ashton Lakes Residences and adjacent lands, and the lands of ASHTON LAKES COMMUNITY ASSOCIATION as may be from time to time paved and other portions of the common elements and the lands of ASHTON LAKES COMMUNITY ASSOCIATION intended for such purposes, but the same shall not give or create in any person the right to park upon any portions of the Condominium or Community property except those intended to be used for such purposes and reasonably suited therefor.

(c) Easement for Unintentional and Non-Negligent Encroachments. If a Unit shall encroach upon any common element or upon any other Unit by reason of original construction or by the non-purposeful or non-negligent act of the Unit Owner, then an easement appurtenant to such encroaching Unit, to the extent of such encroachment, shall exist so long as such encroachment shall exist. If any common element shall encroach upon any Unit by reason of original construction or the non-purposeful or non-negligent act of the Association, then an easement appurtenant to such common element, to the extent of such encroachment, shall exist so long as such encroachment shall exist.

(d) Other Easements. All easements over, upon, through and across the

lands comprising this Condominium as set forth in Exhibit "1" attached to this Declaration of Condominium.

(e) Easements. All the easements shown on Exhibit "A" attached to the Declaration of Condominium of ASHTON LAKES, a Condominium, recorded in Official Record Book 1708, pages 116 through 212, both inclusive, of the Public Records of Sarasota County, Florida, which is also Condominium Book 23, pages 4, 4A-4N, both inclusive, and all other easements heretofore set forth with respect to such lands, except that easements on or across the area labeled Recreation Area which appears on Sheet 4 of Exhibit "A", which is also recorded in Official Record Book 1708, page 170, Condominium Book 23, page 4C, and illustrated by the drawing on Sheet 12, Exhibit "A", which is also Official Record Book 1708, page 178, and Condominium Book 23, page 4K, of the Public Records of Sarasota County, Florida, no longer exist.

(f) Maintenance and Repairs. The right to enter over, through and upon all of the Condominium property for the purpose of maintaining, repairing and replacing any portions of the Condominium that are the responsibility of the Association; provided, however, that entry upon a Unit except in the case of an emergency shall be permitted only with the consent of the Unit Owner or pursuant to legal process.

(g) Easements for Construction and Sale. Until such time as Developer has completed the Condominium together with the construction of all permitted improvements, and sold all of the Units contained within the Condominium and the residences to be constructed within the Ashton Lakes Community and adjacent lands, easements including but not necessarily limited to ingress and egress are hereby reserved and shall exist through and over the Condominium property as may be required, convenient or desirable by Developer for the completion of the contemplated development of the Condominium, the permitted improvements thereto, and the sale of Units within the Condominium, the Ashton Lakes Community, and adjacent lands. Neither the Unit Owner nor the Association shall interfere in any manner whatsoever with such completion and sale by Developer.

4.4) Developer's Right to Create Additional Easements. The Developer, and its successors as Developer, retain the right and shall at all times have the right to declare and create, modify and amend, from time to time, by written amendment by the Developer only, without joinder and consent of any Unit Owner, mortgagee, lienor, or of the Condominium Association, reasonable easements upon the Condominium property for drainage or public utility purposes for the Condominium, the Ashton Lakes Community and adjacent lands, and for peaceful ingress and egress to prevent abutting properties from being landlocked or otherwise denied reasonable access to and from the public ways, providing, however, that at the time of the creation of such easements and at the time of the modification or amendment of any such easements, such easements and such modifications and amendments shall not be inconsistent with the peaceful and lawful use and enjoyment of the Condominium property by the owners thereof. The Developer may, by an instrument in writing, relinquish the power and authority herein reserved to create, modify and amend easements, by the filing among the Public Records of Sarasota County, Florida, a written instrument to that effect, from and after the recording of which the Developer and its successors and assigns as Developer shall no longer have the powers and authorities reserved or granted in this Paragraph 4.4).

4.5) Alteration of Boundaries Between and Size of Abutting Units and Interior Design and Layout of Units by Developer. The Developer reserves the right to modify, move, amend, or change the boundaries between abutting units in the condominium for any purpose whatsoever. The Developer shall not change the configuration or size of any condominium unit in any material fashion, materially alter or modify the appurtenances to the unit, or change the proportion or percentage by which the owner of the parcel shares the common expenses and owns the common surplus unless permitted by Article 15 of this Declaration of Condominium. Developer reserves the absolute right to change, modify, or amend the interior design arrangement and layout of all units owned by it. Such changes will not affect units not owned by Developer nor the share of common elements or voting rights.

4.6) Amendment of Declaration to Reflect Alterations of Boundaries or Interior Design. The Developer shall file an amendment to the Plat of Condominium to show a movement or change in the boundaries between abutting units, change in size (except as limited in Paragraph 4.5), interior design, layout, or arrangement of units, so long as said amendment is not in conflict with Section 718.110(4), Florida Statutes. Such

amendment to the Condominium Plat shall be prepared by a licensed Florida surveyor and shall be accompanied by an amendment to the Condominium Plat which need be signed only by the Developer.

4.7) Amendment to Declaration to Reflect Substantial Completion. All persons acting with reference to this Condominium, whether as contract purchasers, grantees, mortgagees, lienors or otherwise, acknowledge and agree that if at the time of the execution and recording of this Declaration and the Exhibits attached hereto and the Condominium Plat, the Condominium is not substantially completed, they agree for themselves and their heirs, grantees, personal representatives, successors and assigns that Developer by itself has the right to amend this Declaration and the Exhibits as may be necessary or desirable from time to time to identify, locate and dimension the improvements, Units and common elements as and when the construction of the Condominium is substantially completed. At such time as the construction of the Condominium is substantially completed, the Declaration shall be amended to reflect such substantial completion and to include the certificate required by Section 718.104(4)(e), Florida Statutes. Such an Amendment when signed and acknowledged by the Developer shall constitute an amendment of this Declaration, without approval of the Association, other Unit Owners or contract vendees, lienors or mortgagees of Units or of the Condominium or any other person, whether or not elsewhere required for amendment. In the event of any variation between the actual situs of a Unit, building or other improvement on the Condominium property and that shown on Exhibit "1", the actual situs of the Unit, building or other improvement shall prevail.

4.8) Location of Roads and Designation of Parking.

(a) Developer expressly reserves the right in its sole discretion, without consent or approval of any unit owner, mortgagee or other lienor, contract vendee, the Association or any other person, to modify, move, amend or change the location of the proposed roads providing ingress and egress to and from the Condominium and/or the location, number and/or dimensions of the proposed parking spaces when deemed necessary by Developer to save existing trees and shrubbery to comply with the Tree Preservation Ordinance of Sarasota County. The Developer shall reflect such a movement, modification, amendment or change in such location number and/or dimensions by an amendment as set forth within preceding paragraph 4.7) of this Declaration.

(b) Areas required for minimum off-street parking by Sarasota County to the maximum extent thereof of twenty-five percent (25%) has, pursuant to current applicable Ordinance of Sarasota County, been placed in reserve in landscape and grassed areas for the purpose of increasing green area and enhancing the esthetics of the Condominium. Developer reserves the right in its sole discretion, without the consent or approval of any unit owners, mortgagees or other lienors, contract vendees, the Association or any other person, if required by the County of Sarasota hereafter to pave, mark, stripe or make any other type of improvement to the reserved area to do so forthwith. Any costs incurred therewith shall constitute a common expense. An easement for the use of such spaces and for access thereto shall exist and run in favor of, in addition to Developer, each condominium unit owner, and those claiming by, through and under them. That portion of such costs attributable to each condominium unit shall be equal to an amount computed by multiplying the total cost thereof by the percentage interest in the common elements attributable to the condominium unit. The provisions of this clause shall constitute a covenant running with the title to the Lands and shall be binding upon any successor in title, and may not be canceled and terminated except by the prior written consent of Developer, its successors and assigns.

4.9) Unit Boundaries. Each Unit shall include that part of the Building containing the Unit which lies within the boundaries of the Unit as defined on Exhibit 2.

(a) Upper and Lower Boundaries. The lower boundary of each Unit is the plane of the unfinished upper surface of the concrete slab serving as the Unit's floor. The upper boundary of the first and second floor Units is the plane of the lower surface of the concrete slab between the upper and lower Units extended horizontally to intersect with perimetrical boundaries of the unit. The upper boundary of the third floor Units is the lower unfinished surfaces of the bottom chord of the trusses.

(b) Perimetrical Boundaries. The perimetrical boundaries of each Unit

are the vertical planes of the interior unfinished surfaces of the concrete block walls and the unfinished interior surfaces of the studs of frame walls bounding the Units extended to intersect with each other and with the upper and lower boundaries.

(c) Unit Elements. A Unit shall also include any balconies, entryways, stoops, sills, outside doors, porches, canopy, windows, glass, screens, water heater, heating and air conditioning equipment, garage door, garage door opener, and any other equipment designed to be used exclusively by a particular Unit. The garage or covered parking described in Paragraphs 5.1(c) and 5.1(d) is a part of the Unit and its boundaries are described above.

The balconies and porches for each Unit are a part of that Unit and not common elements. The porches on the first floor will be screened. The balconies on the second and third floors will be screened. Screening must follow a uniform color, style and material established by the Developer and continued or modified by the Association.

In the event the actual physical location of any Unit at any time does not precisely coincide with the location as shown on Exhibit 2, the actual physical location shall control over locations, dimensions and descriptions contained in Exhibit 2. In the event of a total or substantial destruction of the building, the location, dimensions and descriptions of the respective Units as contained in Exhibit 2 and subsequent amendments will control.

4.10) Common Elements. The common elements of the Condominium include the land and all other parts of the Condominium not within the Units and include, but are not limited, to, the following items:

(a) Any utility areas and installations of all utility services which are available to more than one Unit or to the common elements and which are not owned by the respective utility companies.

(b) Planting areas, planters, grass and shrubs within the Condominium.

(c) All driveways, sidewalks, stairways, elevator, halls, foyers and other means of ingress and egress to the Units, except as hereafter provided as a limited common element.

(d) All mechanical equipment outside the respective Condominium Units, but not the heating and air-conditioning equipment serving each Unit.

(e) All electrical apparatus and wiring, television cables, plumbing pipes and apparatus, telephone wires, communication system and all other ducts, conduits, cables, wire or pipe not within the Units and those within the Units but serving more than one Unit which are not owned by the respective utility companies.

(f) All structural beams, posts and members, pipe chases and duct chases within a Unit and an easement of support in any portion of a Unit which contributes to the support of the building.

(g) Alterations, additions and further improvements to the common elements.

(h) Any lands owned by the Association and submitted to condominium ownership by an amendment to this Declaration approved and executed as provided herein for amendments generally, pursuant to the provisions of Section 718.110(6), Florida Statutes.

Not Common Elements. The entryway, roads, streets, parking not assigned, lawns, gardens, shrubs, trees, water and sewer mains and related facilities, utility services not owned by others, ditches, lakes and all other drainage facilities, the administration building, clubhouse, pool, tennis courts and picnic area, and any other utilities which are not metered to the individual Units not located on Condominium property are not common elements, but may be used by the Owners as part of ASHTON LAKES Facilities.

4.11) Restraint Upon Separation and Partition of Common Elements.

(a) The undivided share in the common elements which is appurtenant to a Unit shall not be separated from it and shall pass with the title to the Unit, whether or not separately described.

(b) The share in the common elements appurtenant to a unit cannot be conveyed or encumbered except together with a Unit.

(c) The shares in the common elements appurtenant to Units are undivided, and no action or partition of the common elements shall lie.

The Unit Owners in the aggregate shall be entitled to equal and full use and enjoyment of all the common elements, except the limited common elements and except as they may be restricted by the reasonable and uniform regulations duly adopted by the Association Board of Administration, which usage shall always be in recognition of the mutual rights and responsibilities of each of the Unit Owners.

4.12) Limited Common Elements. The limited common elements of the Condominium are as follows:

Courtyards: Courtyards for the first floor units are limited common elements appurtenant to each unit reserved for the exclusive use of the Unit to the exclusion of all other Units within the Condominium. Use, however, shall be subject to right of access for ingress and egress over, across and through the courtyard by the Association, its representatives, agents and independent contractors when necessary for maintenance, repair and/or replacement of a Common Element or to a Unit within the Building.

Carports: Carports are described at Paragraph 5.1(d).

4.13) Time-Share Estates. Time-share estates will not be created with respect to any Units within this Condominium.

ARTICLE 5.
Units, Appurtenances & Expenses

5.1) Appurtenances to Units. The Owner of each Unit shall own a share and certain interests in the Condominium property, which is appurtenant to each Unit and shall include but not limited to the following:

(a) Common Elements and Common Surplus. An undivided one-twenty-fourth (1/24th) share in the land and other common elements of the Condominium and in the common surplus.

(b) Ashton Lakes Community Association. The Owners of each Unit in the Condominium shall be, by reason of such ownership, owners of an undivided interest in the ASHTON LAKES COMMUNITY ASSOCIATION.

(c) Covered Garage. Each unit in Building 2 shall have one (1) enclosed garage which is a part of the Unit, except that units 5619, 5621, 5623, 5625, 5627 and 5629 shall have one (1) carport. Such garage passes as part of the conveyance of a Unit without further description, and may not be separated from the Unit.

The garage which is appurtenant to a unit has the same number on the condominium plat as the unit.

(d) Carports. Units 5619, 5621, 5623, 5625, 5627 and 5629 of Building 2 shall have one (1) carport which shall be a limited common element appurtenant to the Unit and shall be for the exclusive use and enjoyment of the owner/occupant of such Unit. A sale or transfer of the Unit shall automatically, without specifically mentioning such carport and without any further instruments being filed, pass as part of the conveyance of a Unit to the new owner without further description. The carport which is a limited common element appurtenant to a Unit has the same number on the Condominium Plat as the Unit.

(e) Easement for Air Space. An exclusive easement for the use of the air space occupied by the Unit as it exists at any particular time and as the Unit may lawfully be altered or reconstructed from time to time. An easement in air space

which is vacated shall be terminated automatically.

5.2) Liability for Common Expenses. Each Unit Owner shall be liable for a one-twenty-fourth (1/24th) share of the common expenses and assessments.

ARTICLE 6.
Maintenance, Alteration and Improvement

6.1) Maintenance, Alteration and Improvement. The responsibility for the maintenance of the Condominium property and restrictions upon the alteration and improvements thereof shall be as hereinafter provided, and subject to the restrictions as set forth in the Articles of Incorporation, Bylaws and Declaration of Covenants and Restrictions of ASHTON LAKES COMMUNITY ASSOCIATION.

6.2) By the Association. The Association shall maintain, repair and replace at the Association's expense:

(a) All portions of a Unit, except interior surfaces, contributing to the support of the building, which portions shall include but not be limited to outside walls of buildings, roofs, floor and ceiling joists and slabs and load-bearing columns and load-bearing walls;

(b) All conduits, ducts, pipe chaser and duct chaser, plumbing, wiring and other facilities for the furnishing of utility services contained in the portions of a Unit maintained by the Association, and all such facilities contained within a Unit that service part or parts of the Condominium other than or in addition to the Unit within which contained;

(c) All of the common elements and limited common elements, except those limited common elements to be maintained by the unit owner as herein provided;

(d) All incidental damage caused to a Unit by such work shall be repaired promptly at the expense of the Association;

6.3) By the Unit Owner. The responsibility of the Unit Owner shall be as follows:

(a) To maintain, repair and replace, at his expense, all portions of his Unit (except the portions to be maintained, repaired and replaced by the Association), including, but not limited to: paint, finish, covering, wallpaper and decoration of all interior walls, floors and ceiling; all built-in shelves, cabinets, counters, storage areas and closets; all refrigerators, stoves, ovens, disposals, dishwashers and other kitchen equipment; all bathroom fixtures, equipment and apparatus; all windows, screens, screen-doors and lanai screens; all landscaping and plantings located within the interior of a unit; all interior doors; non-load bearing and non-structural partitions and room dividers; and all furniture, furnishings and personal property contained within the respective unit.

(b) To maintain, repair and replace, at his expense, all air-conditioning and heating equipment serving his Unit, his garage door and garage door opener, whether located inside or outside of the boundaries of his Unit.

(c) Not to paint or otherwise decorate or change the appearance of any portion of the exterior of the Unit.

(d) To promptly report to the Association any defect or need for repairs for which the Association is responsible.

(e) Limited Common Elements and all expenses connected therewith shall be the responsibility of the unit owner.

6.4) Alteration and Improvement. Except as elsewhere specifically reserved to the Developer, neither a Unit Owner nor the Association shall make any alterations in the portions of a Unit that are to be maintained by the Association, or remove any portion of such, or make any additions to the, or do anything that would jeopardize the safety or soundness of the Unit, or impair any easements, without first obtaining the approval in writing of owners of all Units in which such work is to be done, and the

approval of the Board of Administration of the Association. A copy of plans for all such work prepared by an architect licensed to practice in this State, shall be filed with the Association prior to the start of the work.

6.5) Common Elements, By the Association. The maintenance, replacement, repair and operation of the Common Elements and Limited Common Elements, except those limited common elements to be maintained by the Unit Owner, shall be the responsibility of the Association as a Common Expense.

6.6) Alteration and Improvements of Common Elements. There shall be no alteration or further improvement of common elements without prior approval in writing of fifty five percent (55%) of all the Unit Owners.

6.7) Hurricane Shutter Specifications. The Board of Administration shall adopt hurricane shutter specifications for each building within each condominium operated by the Association which shall include color, style, and other factors deemed relevant to the Board. All specifications adopted by the Board shall comply with the applicable building code.

6.8) Display of United States Flag. Any Unit Owner may display one (1) portable, removable United States flag in a respectable way and display in accordance with the provisions set forth under Article 10 of this Declaration of Condominium.

6.9) Alterations and Improvements of Limited Common Elements. Courtyards for the first floor Units may be screened in accordance with specifications adopted or approved by the Board.

ARTICLE 7.
Assessments

7.1) Assessments. The making and collection of assessments against the Unit Owners of ASHTON LAKES NO. 9, a Condominium, for common expenses of the Condominium and each owner's share of the expenses of ASHTON LAKES COMMUNITY ASSOCIATION shall be pursuant to the Declaration of Condominium and Bylaws of the Condominium, and the Declaration of Covenants And Restrictions and the Bylaws of ASHTON LAKES COMMUNITY ASSOCIATION.

7.2) Share of Common Expenses. Each Unit Owner, regardless of how the title has been acquired, including by purchase at a foreclosure sale or by deed in lieu of foreclosure, shall be liable for the share of the common expenses set forth in Paragraph 4.2(d) hereof, together with the Unit Owner's share of the common expenses of ASHTON LAKES COMMUNITY ASSOCIATION. Additionally, a Unit Owner is jointly and severally liable with the previous Owner for all unpaid assessments up to the time of transfer of title. This liability is without prejudice to any right the Unit Owner may have to recover from the previous Owner the amounts paid by the Unit Owner. If any unpaid share of common expenses or assessments is extinguished by foreclosure of a superior lien or by a deed in lieu of foreclosure thereof, the unpaid share of common expenses or assessments are common expenses collectible from all the Unit Owners in the Condominium in which the Unit is located.

7.3) Annual Budget of Common Expenses. The Annual Budget of Common Expenses shall be adopted by the Board of Administration of the Association and shall include the owner's share of the expenses of ASHTON LAKES COMMUNITY ASSOCIATION to be collected by the Condominium.

7.4) Interest; Application of Payments. Assessments and installments of such assessments paid on or before ten (10) days after the date when due shall not bear interest, but all sums not paid on or before ten (10) days after the date when due shall bear interest at the rate of eighteen percent (18%) per annum from the date when due until paid and the Association may charge an administrative late fee in addition to such interest, in an amount not to exceed the greater of Twenty-Five Dollars (\$25.00) or five percent (5%) of each installment of the assessment for each delinquent installment that the payment is late. All payments upon account shall be first applied to interest, then to any administrative late fee, then to any costs and reasonable attorneys' fees incurred in collection and then to the assessment payment first due. All interest collected shall be credited to the general expense account.

7.5) Lien for Assessments. The Association has a lien on each Condominium Unit to secure the payment of assessments, interest and administrative late fee as provided by the Condominium Act which shall also secure taxable court costs and reasonable attorneys' fees incurred by the Association incident to the collection of such assessment or preparation, enforcement and foreclosure of such lien, whether suit is filed or not and whether for negotiations, trial, appellate or other legal services.

7.6) Receiver. Upon default in payment of assessments, the Association may apply, by ex parte motion, to a court of competent jurisdiction for the appointment of a receiver to take possession of the Unit, collect the rents and pay therefrom expenses and costs of the Unit including maintenance fees, costs and attorneys fees to the Association, and pay the balance as directed by the Court.

7.7) Continuing Liability for Assessments. A Unit Owner, regardless of how title is acquired, including a purchaser at a judicial sale, shall be liable for all assessments coming due while he is the Unit Owner. In any voluntary conveyance, the grantee shall be jointly and severally liable with the grantor for all unpaid assessments against the grantor for his share of the common expenses up to the time of the conveyance, without prejudice to any right the grantee may have to recover from the grantor the amounts paid by the grantee. The liability for assessments may not be avoided by waiver of the use or enjoyment of any common elements or by abandonment of the Unit for which the assessments are made.

7.8) Lien by Community Association. ASHTON LAKES COMMUNITY ASSOCIATION has a lien on each Unit in the Condominium to secure the payment of assessments due ASHTON LAKES COMMUNITY ASSOCIATION and ASHTON LAKES NO. 9 CONDOMINIUM with interest at the highest rate provided by law, any administrative late fee, and for reasonable attorney's fees incurred by ASHTON LAKES COMMUNITY ASSOCIATION which are incident to the collection of the assessments, or preparation, enforcement and foreclosure of such lien, whether suit is filed or not and whether for negotiations, trial, appellate or other legal services.

All the provisions set forth in the preceding Paragraphs 7.4 through 7.7 respect to assessments as they relate to the condominium shall also apply to assessments by ASHTON LAKES COMMUNITY ASSOCIATION. The liability for assessments due ASHTON LAKES COMMUNITY ASSOCIATION may not be avoided by waiver of the use or enjoyment of any common elements or by abandonment of the Unit for which the assessments are made.

7.9) Enforcement of Liens. The lien is effective from the recording of the original Declaration of Condominium. However, as to first mortgages of record, the lien is effective from and after recording of a claim of lien.

(a) The ASHTON LAKES COMMUNITY ASSOCIATION or the ASHTON LAKES NO. 9 CONDOMINIUM ASSOCIATION may bring an action in its name to foreclose the liens for assessments provided herein in the manner a mortgage on real property is foreclosed and may also bring an action to recover money judgment for the unpaid assessments without waiving any Claim of Lien. The Associations shall be entitled to recover their reasonable attorneys' fees incurred in either a lien foreclosure action or an action to recover a money judgment for unpaid assessments. Each Unit Owner by taking title to his or her Unit grants to the Associations a lien against all rents due and to become due during such period, that any assessments are due and outstanding and does appoint the Associations as receiver for the purpose of receiving such rents paying to the Associations the assessments due and remitting the balance to the Unit Owner. The ASHTON LAKES COMMUNITY ASSOCIATION shall have first priority in which to claim and enforce a lien or collection for unpaid assessments. If the ASHTON LAKES COMMUNITY ASSOCIATION fails to maintain such an action or collection efforts within sixty (60) days after written request of the ASHTON LAKES NO. 9 CONDOMINIUM ASSOCIATION, the ASHTON LAKES NO. 9 CONDOMINIUM ASSOCIATION shall be entitled to initiate collection efforts on behalf of both Associations.

When the Association is unable or unwilling to remit to the COMMUNITY ASSOCIATION a Unit Owner's assessment due the COMMUNITY ASSOCIATION, the Unit Owner may pay such assessment directly to the ASHTON LAKES COMMUNITY ASSOCIATION provided the COMMUNITY ASSOCIATION approves such payment. Such payment by a Unit Owner to the COMMUNITY ASSOCIATION shall be credited against the assessment due the ASSOCIATION.

(b) The Claim of Lien shall describe the Condominium Unit, the name of

the record owner, the name and address of the Association(s), the amount due, and the due dates. No such lien shall be effective longer than one (1) year after the Claim of Lien was recorded unless, within that time, an action to enforce the lien is commenced. The one-year period shall automatically be extended for any length of time during which the Association(s) is prevented from filing a foreclosure action by an automatic stay resulting from a bankruptcy petition filed by the Unit Owner or any other person claiming an interest in the Unit. The Claim of Lien shall secure all unpaid assessments, interest, and administrative late fees which are due and which may accrue subsequent to the recording of the Claim of Lien and prior to the entry of a Certificate of Title, as well as interest and all reasonable costs and attorneys' fees incurred by the Association incident to the collection process. A Claim of Lien must be signed and acknowledged by an officer or authorized agent of ASHTON LAKES COMMUNITY ASSOCIATION and/or ASHTON LAKES NO. 9 CONDOMINIUM ASSOCIATION. Upon making payment in full, the person making the payment is entitled to satisfaction of the lien.

7.10) Payment of Assessments by Acquiring Party. Any person acquiring title to a Unit shall pay the amount owed to the Association(s) within thirty (30) days after transfer of title. Failure to pay the full amount due shall entitle the Association(s) to record a Claim of Lien against the Unit and proceed in the same manner as provided herein for the collection of unpaid assessments.

ARTICLE 8.
Association

8.1) Association. The operation of the Condominium shall be by ASHTON LAKES NO. 9 CONDOMINIUM ASSOCIATION, INC.

8.2) Articles of Incorporation. A copy of the Articles of Incorporation of the Association is attached as Exhibit "B".

8.3) Bylaws. The administration of the Association and the operation of the Condominium property shall be governed by the Bylaws, a copy of which is attached as Exhibit "C".

8.4) Powers. The Association shall have all of the powers and duties reasonably necessary to operate the Condominium property as set forth in the Condominium Act, this Declaration and the Articles of Incorporation and Bylaws of the Association, and as the same may be amended. It shall also have the power subsequent to the recording of this Declaration to acquire and enter into agreements whereby it acquires ownership in fee or otherwise, leaseholds, memberships and other possessory or use interest in real and personal property, including, but not limited to country clubs, club houses, golf courses, marinas, parks, and other recreational facilities, whether or not contiguous to the lands of the Condominium, intended to provide for the enjoyment, recreation or other use or benefit of Unit Owners and to declare the expenses of rental, membership fees, operations, replacements and other undertakings in connection therewith to be common expenses and may make such covenants and restrictions respecting the use of the facilities not inconsistent with the Condominium Act as may be desired. The Association shall also have the power to contract for the management of the Condominium and to delegate to the contractor all of the powers and duties of the Association except such as are specifically required by this Declaration or by the Bylaws to have the approval of the Board of Administration or the membership of the Association.

8.5) Limitation Upon Liability of Association. Notwithstanding the duty of the Association to maintain and repair parts of the Condominium property, the Association shall not be liable to Unit Owners for the injury or damage, other than the cost of maintenance and repair, caused by any latent condition of the property to be maintained by the Association, or caused by the elements or other Owners or persons.

8.6) Restraint Upon Assignment of Shares and Assets. The share of a member in the funds and assets of the Association cannot be assigned, hypothecated, encumbered or transferred in any manner, except as an appurtenance to his Unit.

8.7) Approval or Disapproval of Matters. Whenever a decision of a Unit Owner is required upon any matter, whether or not the subject of an Association meeting, such decision shall be expressed by the same person who would cast the vote of such owner in an Association meeting, unless the joinder of all record owners is specifically required by this Declaration, the Articles of Incorporation or the Bylaws.

8.8) Membership and Voting Rights. All Unit Owners are and must be members of the Association. The owner(s) of each Unit shall be entitled to cast one (1) vote for each Unit owned as provided in the Bylaws.

8.9) Board of Administration. The Board of Administration shall manage and operate the condominium and shall be elected in accordance with provisions of Articles of Incorporation attached as Exhibit B.

The Board of Administration shall have the sole and exclusive right to take all actions, make all decisions, and do all things on behalf of the Association including, but not limited to, the right to enter into contracts on behalf of the Association for the maintenance, operation and management of the Association and the Condominium, the determination, levy and collection of assessments against the Unit Owners, and enactment and enforcement of uniform rules and regulations concerning the ownership, occupancy and use of the Units and the Condominium property.

During the period that the Developer elects a majority of the Board of Administration, administrators so elected need not be unit owners.

ARTICLE 9.
Insurance

9.1 Insurance. The insurance other than title insurance which shall be carried upon the Condominium property and the property of the Unit Owners shall be governed by the provisions hereinafter set forth.

9.2 Authority to Purchase; Named Insured. All insurance policies upon the Condominium property shall be purchased by the Association and the named insured shall be the Association individually and as agent for the Unit Owners, naming them and their mortgagees as their interests may appear. Provision shall be made for the issuance of mortgage endorsements and memoranda of insurance to the mortgagees of Unit Owners. Unit Owners may obtain insurance coverage at their own expense upon their own personal property, for their personal liability and living expense and for those items described in Paragraph 6.3.

9.3) Mortgage Approval. So long as an institutional first mortgagee shall hold a mortgage upon at least a majority of the Units, such mortgagee shall have the right to approve the insurer on all insurance policies covering the Condominium property, and the Association shall submit to said mortgagee proof of payment of the annual premiums on all such insurance policies purchased by the Association. This subparagraph shall be construed as a covenant for the benefit of, and may be enforced by, any such institutional first mortgagee.

9.4) Casualty. All buildings and improvements upon the land and all personal property belonging to the Association or a part of the common elements shall be insured in an amount equal to the maximum insurance replacement value, excluding foundation and excavation costs as determined annually by the Board of Administration of the Association. Such coverage shall afford protection against:

- (a) Loss or damage by fire and other hazards covered by a standard extended coverage endorsement;
- (b) Flood insurance as required by mortgagees; and
- (c) Such other risks as from time to time shall be customarily covered with respect to buildings similar in construction, location and use as the buildings on the land, including, but not limited to, vandalism and malicious mischief.

9.5) Public Liability. Public liability insurance shall be carried in such amounts and with such coverage as shall be required by the Board of Administration of the Association, including, but not limited to, hired automobile and non-owned automobile coverage, and with cross liability endorsement to cover liabilities of the Unit Owners as a group, to a Unit Owner.

9.6) Worker's Compensation. Worker's Compensation insurance shall be carried to meet the requirements of the law.

9.7) Other Insurance. The Association shall carry such other insurance as the Board of Administration shall determine from time to time to be desirable, including flood insurance.

9.8) Premiums. Premiums upon insurance policies purchased by the Association shall be paid by the Association as a common expense.

9.9) Association as Agent. The Association is irrevocably appointed agent for each Unit Owner and for each owner of a mortgage or other lien upon a Unit and for each owner of any other interest in the Condominium property, to adjust all claims arising under insurance policies purchased by the Association, and to execute and deliver releases upon the payment of claims, provided, however, that no claims relating to an individual Unit upon which there is an institutional first mortgage shall be settled without the consent of the institutional mortgagee holding said mortgage, and provided further that if an institutional first mortgagee holding mortgages encumbering more than five (5) Units requests the Association to appoint an independent institutional insurance trustee, the Association shall appoint such a trustee to handle the disbursement of all casualty and property insurance proceeds, and provided further that no claims affecting the common elements in excess of \$25,000 shall be settled without the consent of all institutional first mortgagees.

9.10) Reconstruction and Repair. If any part of the Condominium property shall be damaged by casualty, it shall be reconstructed or repaired immediately unless it is determined in the manner elsewhere provided that the Condominium shall be terminated.

9.11) Plans and Specifications. Any reconstruction or repair must be substantially in accordance with the plans and specifications for the original building, or if not, then according to plans and specifications approved by the Board of Administration of the Association and institutional first mortgagees holding mortgages on the Units involved.

9.12) Responsibility. If the damage is only to those parts of a Unit for which the responsibility of maintenance and repair is that of the Unit Owner, the then Unit Owner shall be responsible for reconstruction and repair after casualty. In all other instances, the responsibility for reconstruction and repair after casualty shall be that of the Association. Insurance proceeds shall be applied to such reconstruction and repair.

9.13) Estimates of Costs. Immediately after a casualty causing damage to property for which the Association has the responsibility of maintenance and repair, the Association shall obtain reliable and detailed estimates of the cost to rebuild or repair.

9.14) Assessments. If the proceeds of insurance are not sufficient to defray the estimated costs of reconstruction and repair by the Association, or if at any time during reconstruction and repair, the funds for the payment of the costs thereof are insufficient, the Association shall pay over sufficient amounts to provide funds to pay the estimated costs, as part of the common expenses of the Association to be assessed against Unit Owners.

9.15) Construction Funds. The funds for payment of costs of reconstruction and repair after casualty, which shall consist of proceeds of insurance and funds collected by the Association from assessments against Unit Owners, shall be disbursed in payment of such costs in the manner required by the Board of Administration of the Association. The first monies disbursed in payment of costs of reconstruction and repair shall be from insurance proceeds, and if there is a balance in the construction fund after payment of all costs of reconstruction and repair for which the fund is established, such balance shall be distributed to the Association as common surplus.

ARTICLE 10.
Use Restrictions

10.1) Use Restrictions. The use of the property of the Condominium shall be in accordance with the provisions hereinafter set forth.

10.2) Prohibitions. No Owner, Tenant or other Occupant of a Unit shall:

(a) Paint or otherwise change the appearance of any exterior wall, door, window, patio, balcony or any exterior surface; place any sunscreen, blind or awning on any balcony or exterior opening; place any draperies or curtains at the windows of any unit without a solid, light color liner acceptable in color to the Board of Administration facing the exterior of the Unit; tint, color or otherwise treat or apply anything to any window which will adversely affect the uniform exterior appearance of the Building in the opinion of the Board; plant any planting outside of a Unit except upon written approval of the landscaping plan by the Board of Administration of the Association; erect any exterior lights or signs; place any signs or symbols in windows; erect or attach any structures or fixtures within the common elements; nor any of the foregoing without the prior written consent of the Board.

(b) Make any structural alterations (except the erection or removal of non-support carrying interior partitions wholly within the Unit) to any Unit or to the common elements.

(c) Permit loud and objectionable noises or obnoxious odors to emanate from the Unit nor play any organ or electronically amplified musical instruments or devices which may cause a nuisance to the occupants of other Units in the sole opinion of the Board, nor allow any musical instruments or device to be placed against a common party wall to another Unit.

(d) Fail to conform and abide by the Declaration Of Covenants and Restrictions, Articles of Incorporation, Bylaws, and Rules and Regulations of ASHTON LAKES Community Association, and the uniform rules and regulations in regard to the use of the Units, the common elements, and the common facilities operated by ASHTON LAKES COMMUNITY ASSOCIATION which may be adopted from time to time by the Board of Administration of the condominium or ASHTON LAKES COMMUNITY ASSOCIATION, or fail to allow the Association and its administrators, officers or designated agent to enter the unit as provided by Section 718.111(5), Florida Statutes.

(e) Erect, construct or maintain any wire, antennas, garbage or refuse receptacles or other equipment or structures on the exterior of the Building or on or in any of the common elements, except with the written consent of the Association Board of Administration.

(f) Obstruct the common way of ingress or egress to the other Units or the common elements.

(g) Hang any laundry, garments or other unsightly objects which are visible outside of the Unit.

(h) Allow anything to remain in the common elements which would be unsightly or hazardous.

(i) Allow any rubbish, refuse, garbage or trash to accumulate in places other than the receptacles provided therefor, and each Unit and the common elements shall at all times be kept in a clean and sanitary condition.

(j) Make use of the common elements in such a manner as to abridge the equal rights of the other Unit Owners to their use and enjoyment.

(k) Except as provided herein, allow any animals to be kept in the unit other than one (1) dog or one (1) cat and fish within aquariums or birds within cages, pursuant to the rules and regulations of the Board of Administration of the Association, provided that in the event such animals become a nuisance to the other Unit Owners in the sole opinion of the Board of Administration, such animals shall be

removed from the Unit immediately; or allow any authorized pets to use the common elements except those areas specifically set aside for pets when on a leash accompanied by its Owner, and any animal waste shall be collected and disposed of by the Owner. Occupancy by any number of animals or by an animal not provided for hereinabove shall occur only if prior written consent shall be given by the Association Board of Administration.

(l) Park overnight or use for a living accommodation commercial vehicles, boats, campers, trailers, mobile homes and similar vehicles in any parking area. Service vehicles during the time they are actually serving the Unit or common elements and pick-up trucks, vans and other personal use vehicles of persons occupying the Units are permitted. Motorcycles are prohibited. Ashton Lakes Community Association will provide guest parking and may establish parking and rules with respect to above vehicles.

(m) Conduct any motor repair or other repair work to an automobile either within the limited common element or common elements of the Condominium nor store any household articles, furnishings or furniture within the parking space or outside the Unit.

(n) Discharge any rubbish, refuse, garbage, animal or human wastes into the lake(s) or onto the embankments or onto or into any common or limited common element area or permit the accumulation of any rubbish, refuse, garbage within any limited common element or common element area of the Condominium.

(o) Remove, prune, cut, damage or injure any trees or other landscaping provided within the Condominium.

(p) Allow any lien pursuant to the Construction Lien Law for labor performed on or materials furnished to his Unit against any other Unit or Condominium parcel of any other Unit Owner not expressly consenting to or requesting such labor or materials or against the common elements.

(q) Fail to pay timely ad valorem taxes and special assessments by taxing authorities assessed against the Condominium parcel and not upon the Condominium property as a whole.

(r) Prevent access by the Association to the Condominium Unit during reasonable hours, when necessary for the maintenance, repair or replacement of any common elements or for making emergency repairs necessary to prevent damage to the common elements or to another Unit or Units within the Condominium.

(s) Permit the playing, lounging, parking and storing of personal property including, but not limited to, baby carriages, strollers, playpens, bicycles, tricycles, wagons, toys, other vehicles, benches, chairs on any part of the common elements or within the parking area without the prior consent of, and subject to any regulations of, the Board of Administration.

(t) Fail to pay promptly for damage due to the act or neglect of the Unit Owner, or of a member of his family or household pet or of a guest or other authorized occupant or visitor of such Unit Owner caused to the common elements or to a Unit or Units owned by others, or the maintenance, repair or replacement required by reason of such damage, as such payment shall be determined by the Board of Administration, to the extent not covered by insurance, if any.

(u) All second floor and third floor units must install and use only carpeting or soft vinyl floor covering. No hard surfaced floor covering such as, but not limited to, ceramic, quarry, slate tile shall be permitted in the living room, dining room, halls, bedrooms or closets of any second floor unit, but the Developer may install and the Association may permit such hard surface floor covering in the foyer, kitchen and baths provided appropriate sound-deadening or absorbing material is laid under the hard surface.

10.3) Residential Units. Each of the Units shall be occupied only by the Owner, his tenants, servants and guests, and the respective families and guests of the Owner and his tenants, as a temporary or permanent residence and for no other purpose, provided, however, that this restriction and limitation shall not prevent or be deemed

to prevent the conveyance of a Unit to two or more persons unrelated by family ties or to a corporation, trust, partnership or other business entity. Except as reserved to Developer, no Unit may be divided or subdivided into a smaller Unit nor any portion thereof sold or otherwise transferred without first amending this Declaration to show the changes in the Units to be affected thereby.

10.4) Common Elements. The common elements shall be used only for the purpose for which they are intended in the furnishing of services and facilities for the enjoyment of the Units.

10.5) Nuisances. No nuisances shall be allowed upon the Condominium property, nor any use or practice which is the source of annoyance to residents or which interferes with the peaceful possession and proper use of the property by its residents.

10.6) Lawful Use. No immoral, improper, offensive or unlawful use shall be made of the Condominium property nor any part thereof; and all valid laws, zoning ordinances and regulations of all governmental bodies having jurisdiction thereof shall be observed. The responsibility of meeting the requirements of governmental bodies which require maintenance, modification or repair of the Condominium property shall be the same as the responsibility for the maintenance and repair of the property concerned.

10.7) Leasing. No Unit may be leased for a period less than thirty (30) days. All leases shall be subject to Association approval as provided by Article 11 of the Declaration. If a Unit Owner is delinquent in the payment of an assessment at the time approval is sought, the Association may disapprove the proposed lease. A Unit may not be leased more than four (4) times in any one (1) calendar year. No rooms or portions of a Unit may be leased. During the time a Unit is leased or occupied by others, the Unit Owner shall not have the right to use the common elements and facilities except as a guest of the lessee. The Association may appoint a rental and sales agent to handle rentals as a convenience to Unit Owners. Such agent shall serve at the pleasure of the Board of Administration and may be replaced at any time.

10.8) Regulations. Reasonable and uniform rules and regulations concerning the use of Units and the Condominium property may be made and amended from time to time by the Association, in the manner provided in the Articles or Bylaws. Copies of such rules and regulations and amendments thereto shall be furnished by the Association to all Unit Owners and occupants of the Condominium on request.

10.9) Provisos. Provided, however, that notwithstanding anything herein contained, until Developer has sold and/or transferred all of the Units in the Condominium, neither the Unit Owners nor the Association nor their use of the Condominium property shall interfere with the sale of the Units. Developer, its agents and employees may make such use of the unsold Units and common elements as may facilitate its completion and sale of units, including, but not limited to, use of roads, streets, parking, maintenance of a sales office, models, the showing of the property, and the display of signs and other advertising.

ARTICLE 11.

Maintenance of Community Interests

11.1) Maintenance of Community Interests. In order to maintain a community of congenial residents who are financially responsible and thus protect the value of the Units, the transfer of Units by any owner other than Developer shall be subject to the following provisions so long as the Condominium exists and the Units in useful condition exist upon the land, which provisions each Unit Owner covenants to observe.

11.2) Transfers Subject to Approval. The following transfers shall be subject to approval:

(a) Sale or Lease. No Unit Owner may dispose of a Unit or any interest therein by sale, other transfer, or lease without the approval of the Association, except to another Unit Owner. The Developer may dispose of a Unit or any interest therein by sale or other transfer without the approval of the Association.

(b) Gift, Devise or Inheritance. If any Unit Owner shall acquire his

title by gift, devise or inheritance or other means of transfer not herein set forth, the continuance of his ownership of his Unit shall be subject to the approval of the Association. This provision shall not be applicable to the immediate family of the initial grantees from the Developer, and for the purposes of this paragraph, the term "immediate family" shall be construed to mean the spouse or children of such original grantee.

11.3) Approval by Association. The approval of the Association which is required for the transfer of ownership of Units shall be obtained in the following manner:

(a) Notice to Association.

(1) Sale or Lease. A Unit Owner intending to make a bona fide sale, transfer, or lease of his Unit shall give to the Association notice of such intention, together with the name and address of the intended purchaser, transferee, lessee, and/or such other information as the Association may reasonably require. Such notice, if a sale, at the Unit Owner's option, may include a demand by the Unit Owner that the Association furnish a purchaser if the proposed purchaser is not approved; and if such demand is made, the notice shall be accompanied by an executed copy of the proposed contract to sell.

(2) Gift, Devise or Inheritance; Other Transfers. A Unit Owner who has obtained his title by gift, devise or inheritance, or by any other manner not heretofore considered, shall give to the Association notice of the acquiring of his title, together with such information concerning the Unit Owner as the Association may reasonably require, and a certified copy of the instrument evidencing the owner's title.

(3) Failure to Give Notice. If the notice to the Association herein required is not given, then at any time after receiving knowledge of a transaction or event transferring ownership or possession of a Unit, the Association at its election and without notice, may approve or disapprove the transaction or ownership. If the Association disapproves the transaction of ownership, the Association shall proceed as if it had received the required notice on the date of such disapproval.

(b) Certificate of Approval. Within thirty (30) days after receipt of such notice and information of a proposed transfer or change of ownership as above set forth, the Association must either approve or disapprove the proposed transaction or continuance of ownership. The Association may provide to the unit owner or purchaser a Certificate of Approval executed on behalf of the Association, in a form suitable for recording in the public records of Sarasota County, Florida. Such certificate and the expense of recording to be provided by the unit owner or purchaser.

(c) Approval of Corporate Owner or Purchaser. Inasmuch as the Condominium may be used only for residential purposes, and a corporation cannot occupy a Unit for such use, if the Unit Owner or purchaser of a Unit is a corporation, the approval of ownership by the corporation may be conditioned upon requiring that all persons occupying the Unit be also approved by the Association.

(d) Fee for Approval. The Association may charge a fee in connection with each request for approval but no such fee shall be in excess of the expenditures reasonably required for the transfer or sale, but such fee shall not exceed the maximum permitted by the Condominium Statute.

11.4) Disapproval by Association. If the proposed transaction is a sale and if the notice of sale given by the Unit Owner shall so demand, or if the Unit Owner giving notice has acquired his title by gift, devise or inheritance [except as provided in Paragraph 11.2)(b) hereof], or in any other manner, and if the Association shall disapprove the transfer of ownership of such Unit, then within 30 days after receipt of such notice and information, the Association shall deliver or mail, by certified mail, to the Unit Owner an agreement to purchase by the Association or by a purchaser approved by the Association who will purchase, said purchaser being an assignee from Association of its rights hereunder, and to whom the Unit Owner must sell the Unit upon the following terms:

(a) If the proposed transaction is a sale, the purchaser shall pay the price as stated in the disapproved contract to sell.

(b) If the Unit Owner has acquired his title by gift, devise, inheritance or in any other manner, the sale price shall be the fair market value determined by agreement between seller and purchaser within 20 days of the delivery or mailing of such agreement and, in the absence of such agreement, by arbitration.

(c) Arbitration shall be in accordance with the then existing rules of the American Arbitration Association, except that the arbitrators shall be two real estate appraisers appointed by the American Arbitration Association who shall base their determination upon an average of their appraisals of the Unit; and a judgment of specific performance of the sale upon the award rendered by the arbitrators may be entered in any court of competent jurisdiction. The expenses of arbitration shall be paid by the purchaser.

(d) The purchase price shall be paid in cash at closing.

(e) The sale shall be closed within 30 days after the delivery or mailing of said agreement to purchase, or within 10 days after the determination of the sale price if such is by arbitration, whichever is the later.

(f) A certificate of the Association executed by its President and Secretary approving the purchase shall be recorded in the Public Records of Sarasota County, Florida, at the expense of the purchaser.

(g) If the Association shall fail to purchase or to provide a purchaser as herein required, or if the Association or a purchaser furnished by the Association shall default in the agreement to purchase, then notwithstanding the disapproval, the proposed transaction or changed ownership shall be deemed to have been approved, and the Association shall furnish a certificate of approval as elsewhere provided, which shall be recorded in the Public Records of Sarasota County, Florida, at the expense of the purchaser or Unit Owner, as the case may be.

(h) If the transaction is a lease, if the approval is not given, the lease shall not be made and the proposed tenant shall not take possession.

11.5) Mortgage. No Unit Owner other than the Developer may mortgage his Unit or any interest therein without the approval of the Association, except to a bank, insurance company, real estate investment trust, Massachusetts business trust, savings and loan association, mortgage banker, mortgage broker, agency of the U. S. Government, or to a vendor to secure a portion or all of the purchase price. The approval of any other mortgagee may be upon conditions determined by the Association or may be arbitrarily withheld.

11.6) Exceptions. The foregoing provisions of this section entitled "Maintenance of Community Interests" shall not apply to a transfer or to a purchase by Developer or by a bank, insurance company, real estate investment trust, Massachusetts business trust, savings and loan association, mortgage banker, mortgage broker, or agency of the U. S. Government that acquires its title as the result of owning a mortgage upon the Unit concerned, and this shall be so whether the title is acquired by deed from the mortgagor or through foreclosure proceedings; nor shall such provisions apply to a transfer or sale by Developer or by a bank, insurance company, real estate investment trust, Massachusetts business trust, mortgage banker, mortgage broker, agency of the U. S. Government or savings and loan association that so acquires its title. Neither shall such provisions require the approval of a purchaser who acquires the title to a Unit at a duly advertised public sale with open bidding provided by law, such as, but not limited to an execution sale, foreclosure sale, judicial sale or tax sale.

11.7) Unauthorized Transactions. Any sale, change of ownership or mortgage which is not authorized pursuant to the terms of this Declaration shall be void unless subsequently approved in writing by the Association.

11.8) Notice of Lien or Suit.

(a) Notice of Lien. A Unit Owner shall give notice, in writing, to the Association of every lien upon his Unit other than for permitted mortgages, taxes and special assessments within 5 days after the attaching of the lien.

(b) Notice of Suit. A Unit Owner shall give notice, in writing, to the

Association of every suit or other proceeding which may affect the title to his Unit, such notice to be given within 5 days after the Unit Owner receives knowledge thereof.

(c) Failure to Comply. Failure to comply with this subsection concerning liens will not affect the validity of any judicial sale.

ARTICLE 12.
Summary of Developer Rights

12.1) Set forth below is a summary of the various rights reserved to the Developer throughout the Declaration of Condominium, Articles of Incorporation and Bylaws of ASHTON LAKES NO. 9, a Condominium, which are designed to permit the Developer to successfully develop, improve and sell the units to be constructed within the condominium as well as units and other forms of single-family residences to be developed throughout the Ashton Lakes Community and any lands adjacent thereto. Failure to include or fully describe any rights reserved to the Developer throughout the Condominium Documents in this Article 12 shall not constitute a limitation or lessening of the rights otherwise provided to the Developer by the Condominium Documents or the laws of the State of Florida.

12.2) The rights reserved to the Developer shall include by way of description and not limitation the following:

- (a) Use of the Administration Building of ASHTON LAKES COMMUNITY ASSOCIATION as a sales office and construction office.
- (b) The right to use the sales office administration building as provided in Article 4, Paragraph 4.2(e)(1).
- (c) The right to alter lakes, ditches and drainage facilities as provided by Article 4, Paragraph 4.2(e)(5).
- (d) Easements as provided by Article 4, Paragraph 4.3 and subparagraphs thereunder.
- (e) The right to guarantee by statement in the Contract of Sale that assessments for common expenses will not exceed a stated amount for a stated period of time as provided by the Florida Condominium Statute. The Developer shall pay the difference between the common expenses and the amount produced by assessments against the Unit Owners, and shall be excused from liability for assessments for unsold units. The Developer does not guarantee that assessments will not increase after the guarantee period.
- (f) The right to control the Condominium Association as provided by Paragraph 8.9.
- (g) The right to amend the Declaration of Condominium to reflect alterations of boundaries or interior design, and to reflect substantial completion as provided by Paragraphs 4.6 and 4.7 respectively.
- (h) The right to change and relocate roads and parking as provided in Paragraph 4.8 (a) and (b).
- (i) The right to sell units without Association approval required by Article 11.
- (j) The right to assign and convey the rights, powers and privileges, easements, reservations, restriction and limitations reserved or created by these Condominium Documents.
- (k) The right to deed by Quit-Claim Deed any portion of the real estate described at Paragraph 3.6 to the Ashton Lakes Community Association.

ARTICLE 13.

Purchase and Lease of Units and Other
Real and Personal Property by the Association

13.1) Purchase by the Association. The Association shall have the power to purchase Units in the Condominium as well as other real and personal property, and leaseholds, memberships and other possessory or use interests, all as provided in Article 8, and to hold, lease, mortgage and convey the same only in accordance with the following provisions:

(a) Decision. A majority of the Board of Administrators and of the Unit Owners shall be required to purchase or lease a Unit in the Condominium, or any other real or personal property, and to mortgage and convey the same.

(b) Limitation. If at any one time the Association is the owner or contract purchaser of three (3) or more Units, it may not purchase any additional Units without the prior written approval of 70% of members eligible to vote thereon. The Association may vote the votes attributable to the Units it owns. Provided, however, that the foregoing limitation shall not apply to Units to be purchased at public sale resulting from a foreclosure of the Association's lien for delinquent assessments where the bid of the Association does not exceed the amount found due the Association, or to be acquired by the Association in lieu of foreclosure of such lien if the consideration therefore does not exceed the cancellation of such lien.

ARTICLE 14.

Compliance and Default

14.1) Compliance and Default. Each Unit Owner shall be governed by and shall comply with the terms of the Declaration of Condominium, Articles of Incorporation, Bylaws and Rules and Regulations adopted pursuant thereto and as said documents and Rules and Regulations may be amended from time to time by the Condominium, together with the Articles of Incorporation, Declaration Of Covenants and Restrictions, Bylaws, and Rules and Regulations of ASHTON LAKES CONDOMINIUM ASSOCIATION, INC. Failure of a Unit Owner to comply with the above shall entitle the Association or other Unit Owners or ASHTON LAKES COMMUNITY ASSOCIATION to the relief hereinafter provided, in addition to the remedies provided by the Condominium Act.

14.2) Right of Access. The Association and its administrators, officers and agents are hereby empowered to enforce this Declaration and the Bylaws and Rules and Regulations of the Association. The Association has the irrevocable right of access to each unit during reasonable hours, when necessary for the maintenance, repair, or replacement of any common elements or for making emergency repairs which are necessary to prevent damage to the common elements or association property.

14.3) Negligence. A Unit Owner shall be liable for the expense of any maintenance, repair or replacement rendered necessary by his act, neglect or carelessness, or by that of any member of his family, or his or their guests, servants, employees, agents or lessees, but only to the extent that such expense is not met by the proceeds of insurance carried by the Association.

14.4) Fines. The Association may levy reasonable fines against a unit for the failure of the owner of a Unit, or its occupant, licensee, or invitee, to comply with any provision of the Declaration, the Association Bylaws, or reasonable rules of the Association. No fine will become a lien against the Unit. No fine may exceed \$100.00 per violation. However, a fine may be levied on the basis of each day of a continuing violation, with a single notice and opportunity for hearing, provided that no such fine shall in the aggregate exceed \$1,000.00. No fine may be levied until after the Association provides reasonable notice and an opportunity for a hearing to the Unit Owner and, if applicable, its licensee or invitee. The hearing shall be held before a committee of other Unit Owners. If the committee does not agree with the fine, the fine may not be levied.

14.5) Costs and Attorneys' Fees. In any proceeding arising because of an alleged failure of a Unit Owner to comply with the terms of the Declaration, the Bylaws or the Rules and Regulations adopted pursuant thereto, and said documents as they may be amended from time to time, or for a declaratory judgment relating to the

rights of the Association or Unit Owners thereunder, the prevailing party shall be entitled to recover the costs and expenses of the proceeding and reasonable attorneys' fees to be awarded by the court, whether for trial or appellate legal services.

14.6) No Waiver of Rights. The failure of the Association or any Unit Owner to enforce any covenant, restriction or other provision of the Condominium Act, this Declaration, the Articles of Incorporation, the Bylaws, or the Rules and Regulations adopted pursuant thereto, shall not constitute a waiver of the right to do so thereafter.

ARTICLE 15.
Amendments

15.1) Amendments. Except as otherwise specifically provided, this Declaration of Condominium may be amended only in the manner hereinafter set forth.

15.2) Notice. Notice of the subject matter of a proposed amendment shall be included in the notice of any meeting at which a proposed amendment is to be considered.

15.3) Resolution of Adoption. A resolution adopting a proposed amendment may be proposed by either the Board of Administration of the Association or by at least thirty percent (30%) of the members of the Association. Administrators and members not present in person or by proxy at the meetings considering the amendment may express their approval in writing, providing such approval is delivered to the Secretary at or prior to the meeting. Except as elsewhere provided, such approvals must be by not less than 50% of the votes of the entire membership of the Association.

15.4) Limitation on Amendment. Provided, however, that no amendment shall discriminate against any Unit Owner nor against any Unit or class or groups of Units unless the Unit Owners so affected shall consent, provided, however, that notwithstanding anything herein contained to the contrary, such amendment(s) shall not be effective until such time as all institutional first mortgagees holding mortgages encumbering more than five (5) Units have consented in writing to such amendment(s) which materially affect the rights or interests of the mortgagees, or as otherwise required by the Federal National Mortgage Association or the Federal Home Loan Mortgage Corporation. Such consent shall not be unreasonably withheld. No amendment shall change the provisions of Article 10.9) entitled "Provisio" or Article 11.6 entitled "Exceptions" without the Developer's consent. Neither shall an amendment make any change in the section entitled "Insurance" nor in the section entitled "Reconstruction or Repair after Casualty", unless the record holders of all mortgages upon the Condominium shall join in the execution of an amendment.

15.5) Execution and Recording. Except as otherwise specifically provided herein, a copy of each such amendment shall be attached to a certificate by the Association certifying that the amendment was duly adopted, which certificate shall be executed by the appropriate officers of the Association with all the formalities of a deed. Any such amendment shall be effective only when such certificate and copy of the amendment are recorded in the Public Records of Sarasota County, Florida.

15.6) Change in Percentage of Ownership in Common Elements or Sharing of Common Expense. Any vote to amend this Declaration relating to a change in the percentage of ownership in the common elements or the sharing of the common expense shall be conducted by secret ballot.

15.7) Creation of Time-Share Estates. No amendment to this Declaration may permit time-share estates to be created in any Unit of the Condominium, unless the record owners of each Unit of the Condominium and the record owners of liens on each Unit of the Condominium shall join in the execution of the amendment.

ARTICLE 16.
Termination

16.1) Termination. The Condominium may be terminated in the manner

hereinafter provided, in addition to the manner provided in the Condominium Act.

16.2) Agreement. The Condominium may be terminated by the approval in writing of all of the Owners of the Units therein, and by all record owners of mortgages thereon. If the proposed termination is submitted to a meeting of the members of the Association, the notice of which meeting gives notice of the proposed termination, and if the approval of the Owners of not less than seventy percent (70%) of the Units and of the record Owners of all mortgages upon the Units, are obtained in writing, not later than thirty (30) days from the date of such meeting, then the approving owners shall have an option to buy all of the Units of the other owners for the period ending on the sixtieth (60th) day from the date of such meeting. Such approvals shall be irrevocable until the expiration of the option, and if the option is exercised, the approvals shall be irrevocable. Such option shall be upon the following terms:

(a) Exercise of Option. The option shall be exercised by delivery or mailing by certified mail to each of the record owners of the Units to be purchased, of an agreement to purchase signed by the record owners of the Units who will participate in the purchase. Such agreement shall indicate which Units will be purchased by each participating owner and shall agree to purchase all of the Units owned by owners not approving the termination, but the agreement shall effect a separate contract between each seller and his purchaser.

(b) Price. The sale price for each Unit shall be the fair market value determined by agreement between the seller and purchaser within thirty (30) days from the delivery or mailing of such agreement, and in the absence of agreement as to price, it shall be determined by arbitration in accordance with the then existing rules of the American Arbitration Association, except that the arbitrators shall be two real estate appraisers appointed by the American Arbitration Association who shall base their determination upon an average of their appraisals of the Unit; and a judgment of specific performance of the sale upon the award rendered by the arbitration may be entered in any court of competent jurisdiction. The expense of the arbitration shall be paid by the purchaser.

(c) Payment. The purchase price shall be paid in cash at closing.

(d) Closing. The sale shall be closed within ten (10) days following the determination of the sale price.

16.3) Certificate. The termination of the Condominium shall be evidenced by a certificate of the Association executed by the President and Secretary certifying as to facts effecting the termination, which certificate shall become effecting upon being recorded in the Public Records of Sarasota County, Florida.

16.4) Shares of Owners after Termination. After termination of the Condominium, the Unit Owners shall own the Condominium property and all assets of the Association as tenants-in-common, in undivided shares, and their respective mortgagees and lienors shall have mortgages and liens upon the respective undivided shares of the Unit Owners. Such undivided shares of the Unit Owners shall be the same as the undivided shares in the common elements appurtenant to the Owners' Unit prior to the termination.

16.5) Amendment. The section concerning termination cannot be amended without consent of all Unit Owners and of all record owners of mortgages upon Units.

16.6) ASHTON LAKES COMMUNITY ASSOCIATION. Termination of the condominium will not terminate the responsibility of the Units in the condominium for their share of the costs and expenses of ASHTON LAKES COMMUNITY ASSOCIATION or their right to use the ASHTON LAKES Community Facilities. Termination of such rights and responsibilities may only be done with the approval of more than seventy-five (75) percent of the Administrators of the ASHTON LAKES COMMUNITY ASSOCIATION.

ARTICLE 17.

Institutional First Mortgagees

17.1) Written Consent Required. Except as otherwise specifically provided

herein, the written consent of all institutional first mortgagees shall be first obtained prior to (1) the subdivision of any Unit; (2) any change in the percentage of ownership of the common surplus or common elements; (3) any change in the percentage of sharing the common expense or assessments; (4) any change in the voting rights; (5) any change in the insurance provisions; and (6) termination of the Condominium. The failure of the Association and Board of Administration to comply with and fully perform the terms of the Condominium documents and the Condominium Act may constitute an actionable default under the terms of any institutional first mortgage, at the election of such institutional first mortgagee.

17.2) Developer's Rights Inure to Benefit of its Designees, Successors and Assigns. All powers, privileges, easements, rights, reservations, restrictions and limitations herein reserved or otherwise created for the benefit of the Developer shall inure to the benefit of the Developer's designees, successors and assigns.

17.3) Acquiring Mortgagee's Responsibility For Accrued and Unpaid Assessments. Notwithstanding anything herein to the contrary, the liability of a first mortgagee or its successors or assigns, who acquires title to a Unit by foreclosure or by deed in lieu of foreclosure, for the unpaid assessments that became due prior to the mortgagee's acquisition of title is limited to the lesser of:

- (a) the Unit's unpaid common expenses and regular periodic assessments which accrued or came due during the six (6) months immediately preceding the acquisition of title and for which payment in full has not been received by the Association; or
- (b) one percent (1%) of the original mortgage debt.

The provisions of this paragraph shall not apply unless the first mortgagee joined the Association as a defendant in the foreclosure action.

17.4) Additional Rights of Institutional First Mortgagees. In addition to all other rights herein set forth, institutional first mortgagees shall have the right, upon written request to the Association, to:

- (a) Examine the Association books and records.
- (b) Receive notice of Association meetings and attend such meetings.
- (c) Receive notice of an alleged default by any Unit Owner for whom such mortgagee holds a mortgage, which is not cured within thirty (30) days of notice of default to such Unit Owner.
- (d) Receive notice of any substantial damage or loss to any portion of the Condominium Property.
- (e) Receive from the Association current copies of the Declaration, Bylaws, Rules and Regulations, and any and all amendments thereto, and to have made available, meaning available for inspection, upon reasonable request, during normal business hours or under other arranged reasonable circumstances, the books, records and financial statements of the Association.
- (f) Receive notice of any condemnation loss that affects either a material portion of the project or the Unit securing its mortgage, and/or lapse, cancellation or material modification of any insurance policy or fidelity bond maintained by the Association.

ARTICLE 18.
Severability

18.1) Severability. The invalidity in whole or in part of any covenant or restriction, or any section, subsection, sentence, clause, phrase or word, or other provision in this Declaration of Condominium and the Articles of Incorporation, Bylaws and Regulations of the Association shall not affect the validity of the remaining portions thereof.

18.2) Notices. All notices to the Association required or desired hereunder

or under the Bylaws of the Association shall be sent by certified mail (return receipt requested) to the Association c/o its office at the Condominium, or to such other address as the Association may hereafter designate from time to time by notice in writing to all Unit Owners. Except as provided specifically in the Act, all notices to any Unit Owner shall be sent by first class mail to the Condominium address of such Unit Owner, or such other address as may have been designated by him from time to time, in writing, to the Association. All notices to mortgagees of Units shall be sent by first class mail to their respective addresses, or such other address, as may be designated by them from time to time in writing to the Association. All notices shall be deemed to have been given when mailed in a postage prepaid sealed envelope, except notices of a change of address, which shall be deemed to have been given when received, or 5 business days after proper mailing, whichever shall first occur.

18.3) Interpretation. The Board of Administrators of the Association shall be responsible for interpreting the provisions hereof and of any of the Exhibits attached hereto. Such interpretation shall be binding upon all parties unless wholly unreasonable. An opinion of counsel that any interpretation adopted by the Association is not unreasonable shall conclusively establish the validity of such interpretation.

18.4) Exhibits. There is hereby incorporated in this Declaration any materials contained in the Exhibits attached hereto which under the Act are required to be part of the Declaration.

18.5) Signature of President and Secretary. Wherever the signature of the President of the Association is required hereunder, the signature of a vice-president may be substituted therefor, and wherever the signature of the Secretary of the Association is required hereunder, the signature of an assistant secretary may be substituted therefor, provided that the same person may not execute any single instrument on behalf of the Association in two separate capacities.

18.6) Governing Law. Should any dispute or litigation arise between any of the parties whose rights or duties are affected or determined by this Declaration, the Exhibits attached hereto or applicable rules and regulations adopted pursuant to such documents, as the same may be amended from time to time, said dispute or litigation shall be governed by the laws of the State of Florida.

18.7) Ratification. Each Unit Owner, by reason of having acquired ownership (whether by purchase, gift, operation of law or otherwise), and each occupant of a Unit, by reason of his occupancy, shall be deemed to have acknowledged and agreed that all of the provisions of this Declaration, and the Articles and Bylaws of the Association, and applicable rules and regulations, are fair and reasonable in all material respects.

18.8) Execution of Documents; Attorney-in-Fact. Without limiting the generality of other Articles of this Declaration and without such other Articles limiting the generality hereof, each Owner, by reason of the acceptance of a deed to such Owner's Unit, hereby agrees to execute, at the request of the Developer, all documents or consents which may be required by all governmental agencies to allow the Developer and its affiliates to complete the plan of development of the project known as "ASHTON LAKES COMMUNITY (of which the Condominium is a part), as hereafter amended, and each such Owner further appoints hereby and thereby the Developer as such Owners' agent and attorney-in-fact to execute, on behalf and in the name of such Owners, any and all of such documents or consents. This power of attorney is irrevocable and coupled with an interest.

18.9) Gender; Plurality. Whenever the context so permits, the singular shall include the plural, the plural shall include the singular, and the use of any gender shall be deemed to include all or no genders.

18.10) Captions. The captions herein and in the Exhibits attached hereto are inserted only as a matter of convenience and for ease of reference and in no way define or limit the scope of the particular document or any provision thereof.

ARTICLE 19.
Waiver

19.1) No provision contained in this Declaration shall be deemed to have been waived by reason of any failure to enforce the same, without regard to the number of violations or breaches which may occur.

ARTICLE 20.
Condemnation Loss

20.1) Distribution of Proceeds. If the Condominium or any portion thereof shall be taken or condemned by any lawful authority having the power to eminent domain, all compensation and damages for or on account of any land shall be payable to and be the sole property of the rightful fee owner and all compensation and damages for or on account of any improvements within such Condominium shall be payable to the Association as agent for the Unit Owners and their respective mortgagees as their interests may appear according to the loss or damages to their respective units and appurtenant common interests and easements and shall be used promptly by and Board of Directors of the Association to the extent necessary for restoration or replacement of such improvements on the remaining land within the Condominium according to plans and specifications pursuant to Article 9.11 hereinabove unless the Association by a vote of not less than seventy percent (70%) of the Unit Owners and institutional first mortgagees holding mortgages on the units involved determine within a reasonable period of time after such taking or condemnation that such restoration or replacement is impractical in the circumstances, in which event the Board of Directors on behalf of the Association and the Association's common expense shall remove all remains of such improvements so taken or condemned and restore the site thereof to good orderly condition and even grade and shall equitably distribute the remaining proceeds from such condemnation or taking to the Unit Owners and their affected mortgagees thereby according to the loss or damage to their respective units and appurtenant common interests and easements.

The Plat of Condominium of ASHTON LAKES NO. 9, a Condominium, is recorded in Condominium Book 30, Pages 38, 38A, 38B, 38C + 38D of the Public Records of Sarasota County, Florida.

IN WITNESS WHEREOF, the Developer has executed this Declaration of Condominium this 1st day of May, 1995.

Witnessed by:

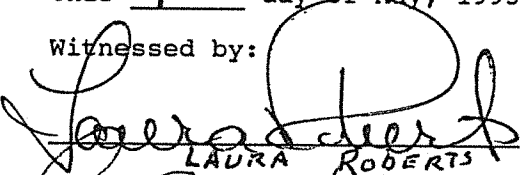
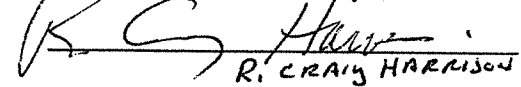

LAURA ROBERTS

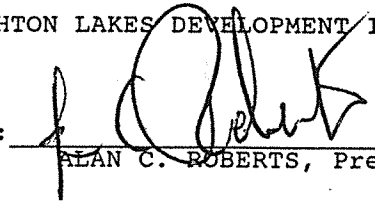
R. CRAIG HARRISON

ASHTON LAKES DEVELOPMENT II, INC.

By: 
ALAN C. ROBERTS, President

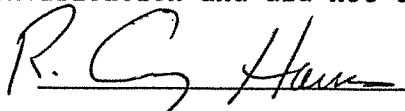
STATE OF FLORIDA
COUNTY OF SARASOTA:

The foregoing instrument was acknowledged before me this 1st day of May, 1995, by ALAN C. ROBERTS, the President of ASHTON LAKES DEVELOPMENT II, INC., a Florida corporation, on behalf of the corporation. He is personally known to me or has produced _____ as identification and did not take an oath.

Notary Public
(printed name)
My Commission No. _____
My Commission expires: _____

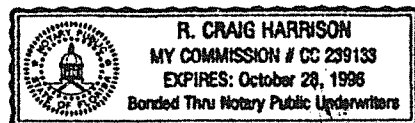

DESCRIPTION

BEGIN at the Southwest corner of Ashton Lakes No. 8, a Condominium, recorded in Condominium Book 30, Page 12 of the Public Records of Sarasota County, Florida; thence S.84°31'44"E., along the Southerly line of said Ashton Lakes No. 8, and the Easterly extension thereof, a distance of 119.72 feet; thence South a distance of 239.45 feet; thence West a distance of 119.18 feet; thence North a distance of 250.86 feet to the POINT OF BEGINNING.

ALSO:

COMMENCE at the Southwest corner of Ashton Lakes No. 8, a Condominium, recorded in Condominium Book 30, Page 12 of the Public Records of Sarasota County, Florida; thence South a distance of 103.88 feet; thence West a distance of 41.01 feet to the POINT OF BEGINNING; thence continue West a distance of 22.00 feet; thence South a distance of 64.00 feet; thence East a distance of 22.00 feet; thence North a distance of 64.00 feet to the POINT OF BEGINNING.

Total described parcel containing 30,625 square feet.

RECORDER'S MEMO: Legibility of writing, typing or printing for reproductive purpose may be unsatisfactory in this document when received.

EXHIBIT 2

A copy of the plot plan of ASHTON LAKES NO. 9, a Condominium, and floor plan of the units is attached to the Prospectus as Item 2.

EXHIBIT A

The Ashton Lakes Community is described at Paragraph 3.6, page 2, of the Declaration of Condominium of ASHTON LAKES NO. 9, a Condominium.

EXHIBIT B

A copy of the Articles of Incorporation of ASHTON LAKES NO. 9 CONDOMINIUM ASSOCIATION, INC. is attached to the Prospectus as Item 3.

EXHIBIT C

A copy of the Bylaws of ASHTON LAKES NO. 9 CONDOMINIUM ASSOCIATION, INC. is attached to the Prospectus as Item 4.

ASHTON LAKES NO. 9
 A CONDOMINIUM
 IN SECTION 9, TOWNSHIP 37 SOUTH, RANGE 18 EAST
 SARASOTA COUNTY, FLORIDA

NOTES

1. BEARINGS SHOWN HEREON ARE RELATIVE TO A BEARING OF N89°56'E FOR THE CENTERLINE OF CLARK ROAD BASED UPON D.O.T. RIGHT OF WAY MAP FOR STATE ROAD NO. 72 (S-782), SECTION NO. 1753-250 RECORDED IN ROAD PLAT BOOK NO. 1, PAGE 46 OF THE PUBLIC RECORDS OF SARASOTA COUNTY, FLORIDA.
2. ELEVATIONS ARE BASED ON THE NATIONAL GEODETIC VERTICAL DATUM OF 1929 ESTABLISHED FROM FLORIDA DEPARTMENT OF NATURAL RESOURCES BM SAR 2 1980 WITH A PUBLISHED ELEVATION OF 4.893447 METERS (16.055 FEET).
3. THE UNIT BOUNDARIES ARE AS FOLLOWS:
 - a. PERIMETRICAL BOUNDARIES:
 THE VERTICAL PLANE OF THE UNFINISHED INTERIOR SURFACE OF THE CONCRETE BLOCK WALLS AND THE UNFINISHED INTERIOR SURFACES OF THE STUCCO WALLS AND CEILING SHALL INTERSECT HORIZONTALLY TO INTERSECT WITH PERIMETRICAL BOUNDARIES.
 - b. UPPER & LOWER BOUNDARIES:
 LOWER - THE PLANE OF THE UPPER SURFACE OF THE UNFINISHED CONCRETE SLAB SERVING AS THE UNIT'S FLOOR.
 UPPER (1ST AND 2ND FLOOR) - THE PLANE OF THE LOWER SURFACE OF THE CONCRETE SLAB EXTENDED HORIZONTALLY TO INTERSECT WITH PERIMETRICAL BOUNDARIES OF THE UNIT.
 UPPER (3RD FLOOR) - THE LOWER UNFINISHED SURFACE OF THE BOTTOM CHORD OF THE TRUSSES.
4. GARAGES ARE PART OF THE UNIT OWNERSHIP OF THE CORRESPONDING NUMBERED UNIT.
5. LIMITED COMMON ELEMENTS ARE AS FOLLOWS:
 - a. COURTYARDS AS SHOWN ON SHEET 3.
 - b. ANY OTHER AREAS AS DESCRIBED IN THE DECLARATION.
6. COMMON ELEMENTS ARE ALL OF THE AREA WITHIN THE DESCRIBED BOUNDARIES NOT DESIGNATED AS UNITS OR LIMITED COMMON ELEMENTS.
7. IMPROVEMENTS WITHIN THE COMMON ELEMENTS SUCH AS, BUT NOT LIMITED TO WATER METERS, WATER LINES, SEWERS, SODWALKS AND TREES HAVE NOT BEEN LOCATED.
8. SUBSTANTIALLY COMPLETED UNITS: NONE

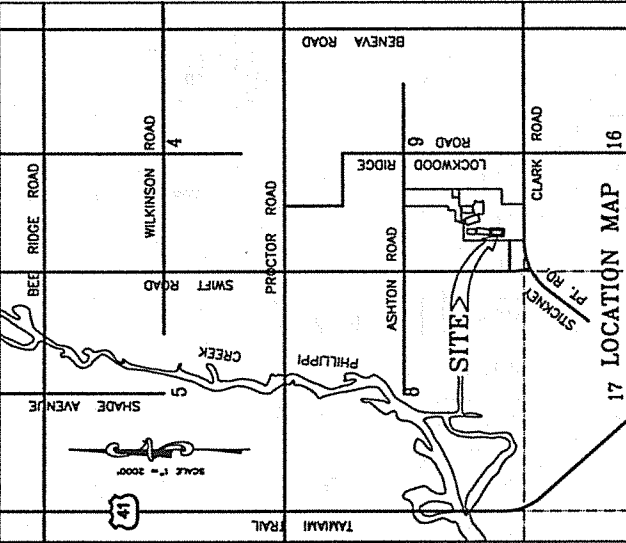

DESCRIPTION

BEGIN at the Southwest corner of Ashton Lakes No. 8, a Condominium, in Condo Book 30, Page 12 of the Public Records of Sarasota County, Florida; thence S.84°31'44"E, along the Southerly line of said Ashton Lakes No. 8, and the Easterly extension thereof, a distance of 119.72 feet; thence South a distance of 239.45 feet; thence West a distance of 119.18 feet; thence North a distance of 250.86 feet to the POINT OF BEGINNING.

ALSO:

COMMENCE at the Southwest corner of Ashton Lakes No. 8, a Condominium, recorded in Condominium Book 30, Page 12 of the Public Records of Sarasota County, Florida; thence South a distance of 103.88 feet; thence continue West a distance of 22.00 feet; thence South a distance of 64.00 feet; thence East a distance of 22.00 feet; thence North a distance of 64.00 feet to the POINT OF BEGINNING.

Total described parcel containing 30,625 square feet.

RECORDER'S MEMO: Legibility of writing, typing or printing for reproductive purpose may be unsatisfactory in this document when received.

CERTIFICATE OF SURVEYOR

I, Robert R. Cunningham, a Professional Land Surveyor, authorized to practice in the State of Florida, hereby certify that this Record of Survey meets the "Minimum Technical Standards for Land Surveying in the State of Florida," Chapter 81G17-6, Florida Administrative Code effective September 1, 1981, and that the construction of the improvements noted in Note 5 are substantially complete so that this material, together with the provisions of the Declaration describing the Condominium property, is an accurate representation of the location and dimensions of the neighborhood common elements and of each unit can be determined from these materials. I further certify that the construction of all planned improvements with respect to units noted in Note 7 are substantially complete including, but not limited to landscaping, utility services, access to the units in sold buildings, and neighborhood common element facilities serving sold buildings.

WILSON, MILLER, BARTON & PEEK, INC.

133 S. MCINTOSH ROAD
 SARASOTA, FLORIDA 34232
 PROJECT NUMBER 2349-16
 WORK ORDER NUMBER: 5618

By: *Robert R. Cunningham*
 Robert R. Cunningham, P.L.S.
 Florida Certificate No. 3924

Date: 5-1-95

(Not valid without embossed seal of certifying surveyor)

CONDOMINIUM BOOK PAGE
 SHEET 2 of 5

ASHTON LAKES NO. 9
 A CONDOMINIUM
 IN SECTION 9, T.37S., R.18E.,
 SARASOTA COUNTY, FLORIDA

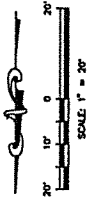

LAKE

- LEGEND**
- = IRON ROD SET - LB 1043
 - = BK. NAIL AND DISK SET IN CONCRETE DRIVE, LB 1043
 - L.C.E. = LIMITED COMMON ELEMENT
 - SQ. FT. = SQUARE FEET

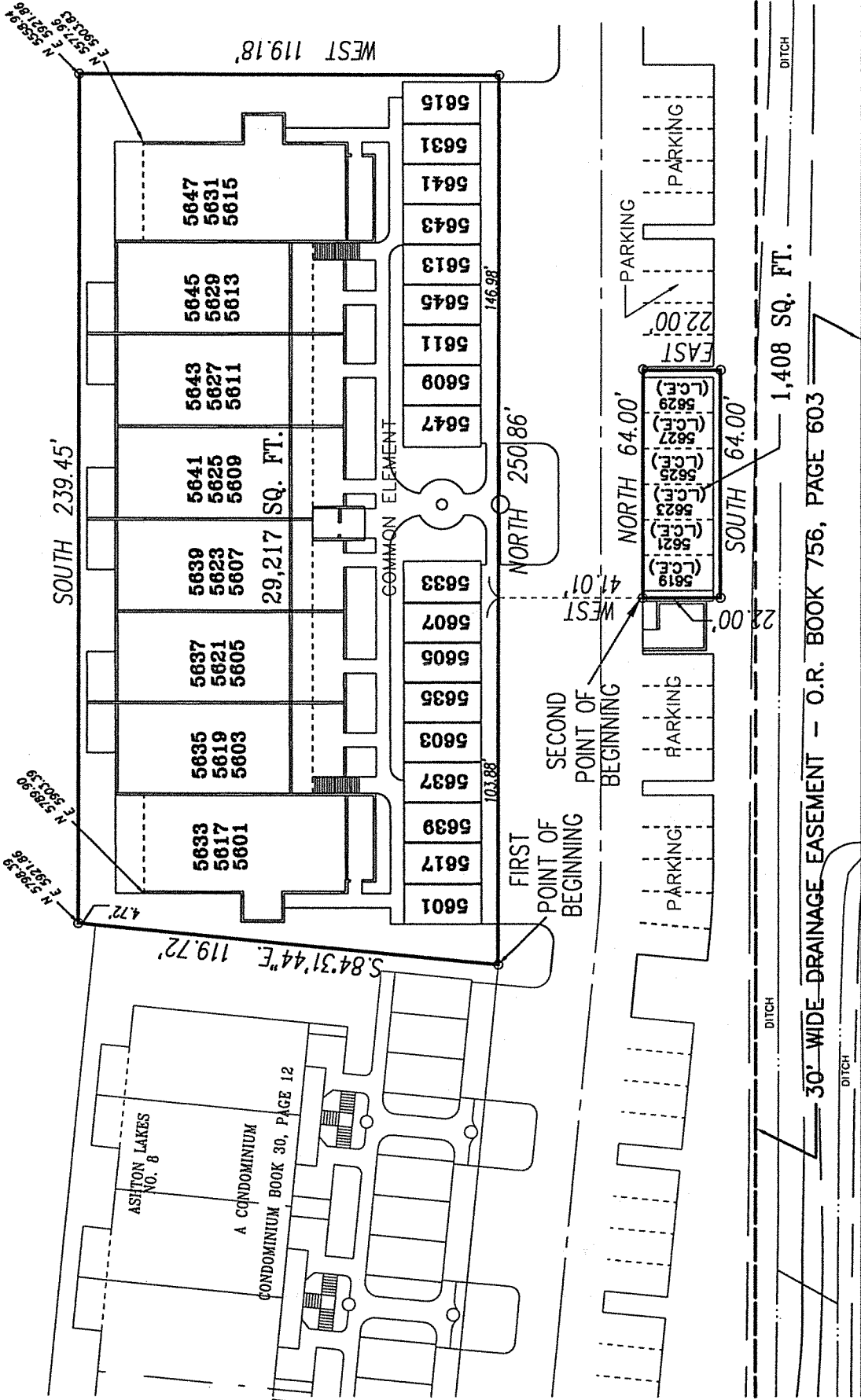

RECORDER'S MEMO: Legibility of writing, typing or
 printing for reproductive purpose may be unsatisfactory
 in this document when received.

WILSON, MILLER, BARTON & PECK, INC.
 133 S. MCINTOSH ROAD
 SARASOTA, FLORIDA, 34232
 PROJECT NUMBER 2349-16
 WORK ORDER NUMBER 5818

ASHTON LAKES NO. 9
A CONDOMINIUM
IN SECTION 9, T.37S., R.18E.,
SARASOTA COUNTY, FLORIDA

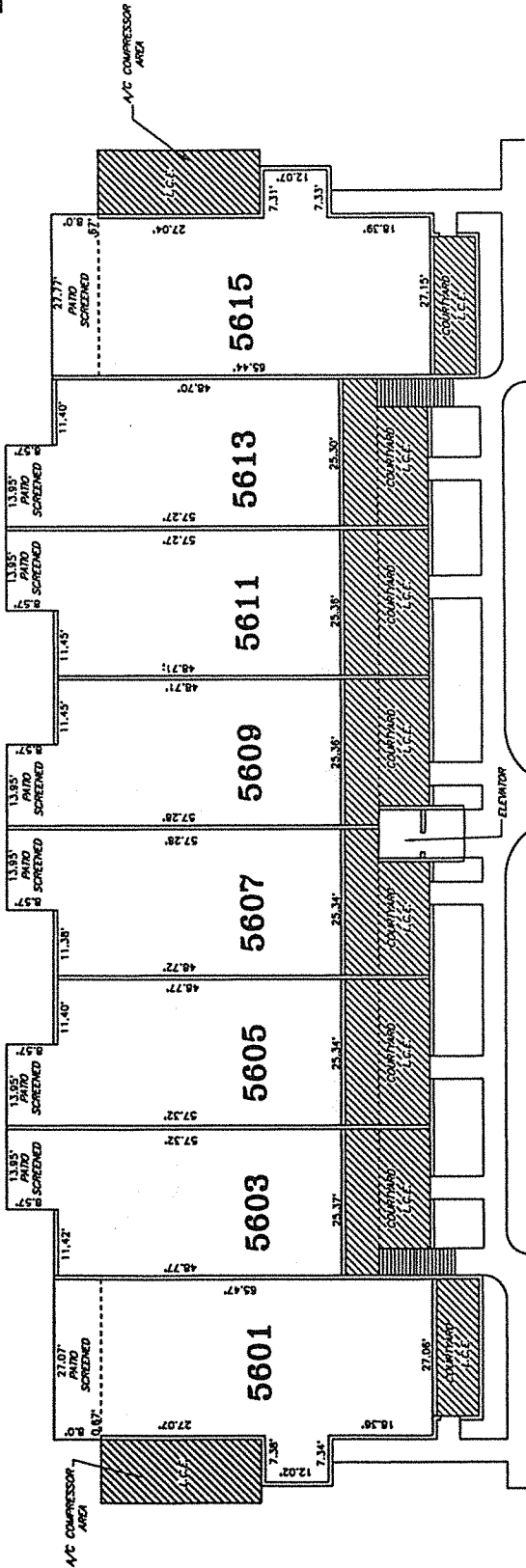
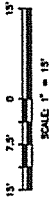

FIRST FLOOR

RECORDER'S MEMO: Legibility of writing, typing or printing for reproductive purpose may be unsatisfactory in this document when received.

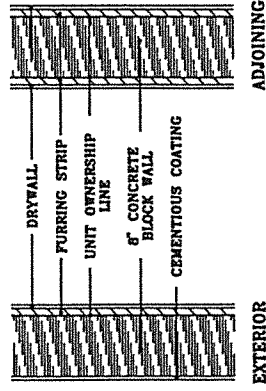

WALL DETAILS

L.C.E. = LIMITED COMMON ELEMENT

[Hatched Box] = LIMITED COMMON ELEMENT

**PERIMETRICAL BOUNDARIES
UPPER & LOWER BOUNDARIES
WALL DETAILS**

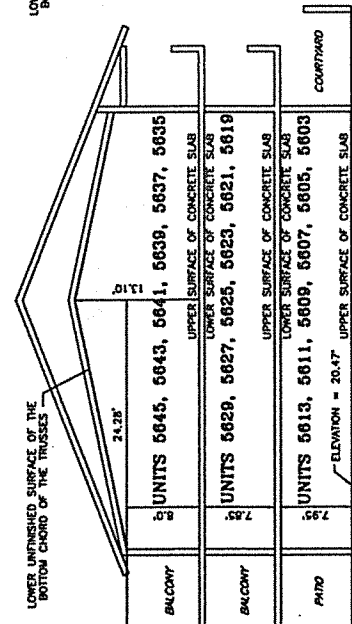
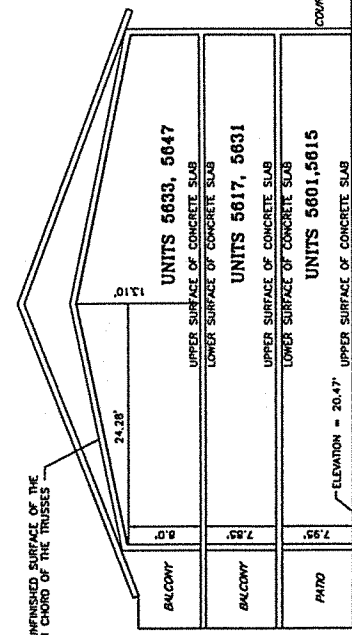

UPPER & LOWER BOUNDARIES

UPPER & LOWER BOUNDARIES

WILSON, MILLER, BARTON & PEEK, INC.
ARCHITECTS - INTERIORS - EXTERIORS - CONSTRUCTION ADMINISTRATION
133 S. MCINTOSH ROAD
SARASOTA, FLORIDA 34232
PHONE NUMBER: 234-1111
WORK ORDER NUMBER: 5818

ASHTON LAKES NO. 9
A CONDOMINIUM
IN SECTION 9, T.37S., R.18E.
SARASOTA COUNTY, FLORIDA

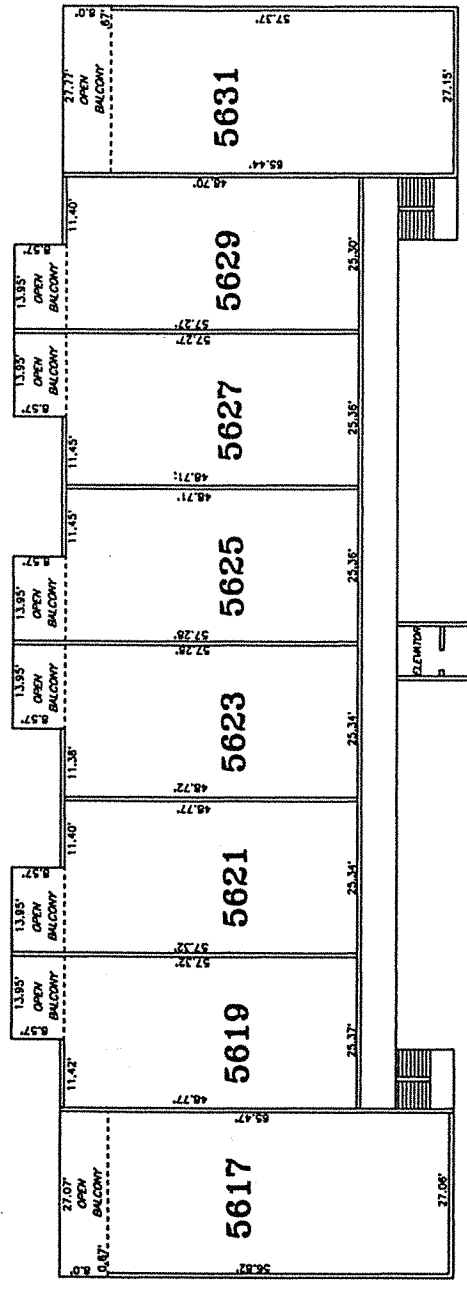
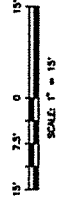

SECOND FLOOR

RECORDER'S MEMO: Legibility of writing, typing or printing for reproductive purpose may be unsatisfactory in this document when received.

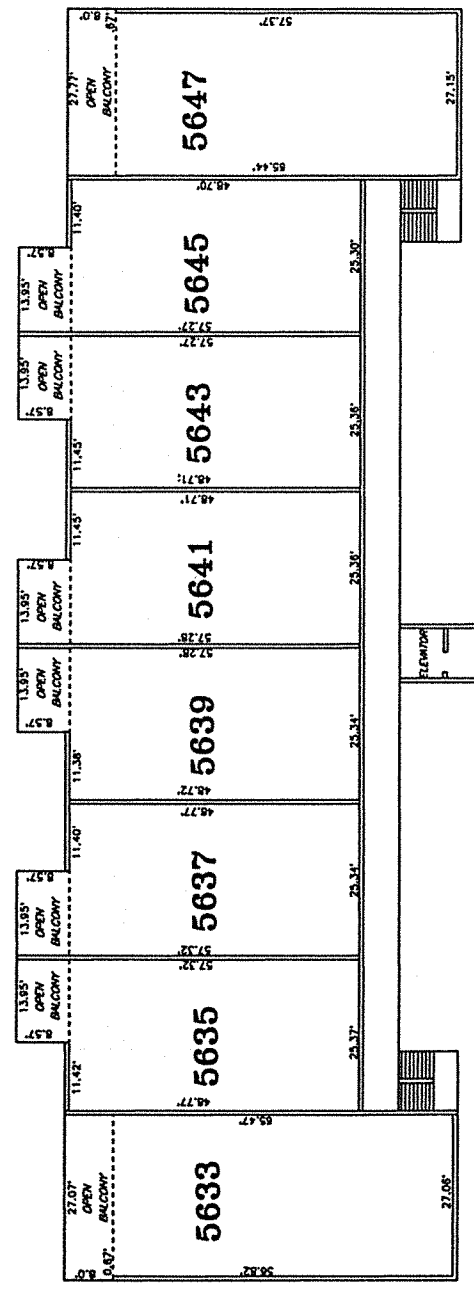

THIRD FLOOR

PERIMETRICAL BOUNDARIES

WILSON, MILLER, BARTON & PECK, INC.
DRAWING - SURVEYOR - PLANNERS - ENGINEERS - ARCHITECTS
LANDSCAPE ARCHITECTS - CONSTRUCTION MANAGERS
133 S. MCINTOSH ROAD
SARASOTA, FLORIDA 34232
PHONE: 941-552-1100
FAX: 941-552-1101
WORK ORDER NUMBER: 5616

ASHTON LAKES NO. 9

A CONDOMINIUM

IN SECTION 9, T.37S., R.18E.,
SARASOTA COUNTY, FLORIDA

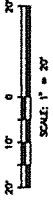

RECORDER'S MEMO: Legibility of writing, typing or printing for reproductive purpose may be unsatisfactory in this document when received.

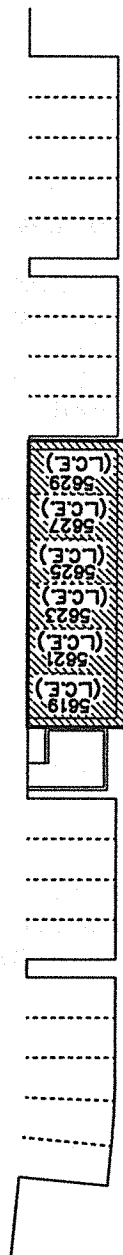
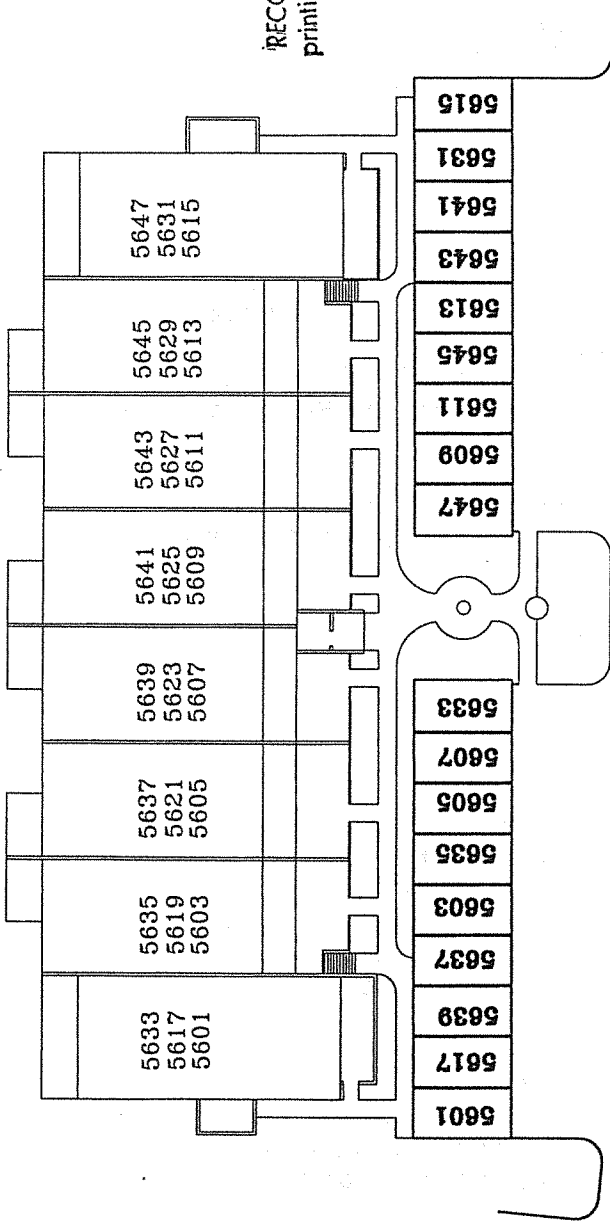

L.C.E. = LIMITED COMMON ELEMENT

PERIMETRICAL BOUNDARIES

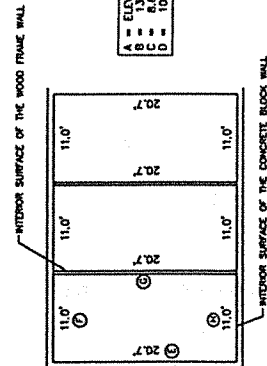

SCALE: 1" = 10'

UPPER & LOWER BOUNDARIES

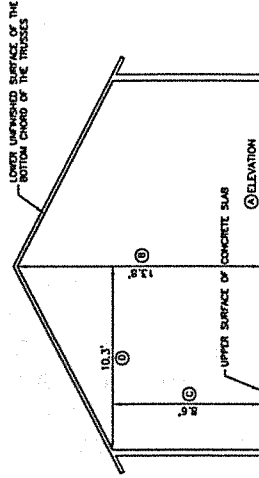

SCALE: 1" = 3'

TYPICAL GARAGE BUILDING

UNIT #	A	B	C	D	E	F	G	H
5601					20.75'			
5617								
5639								
5637								
5603								20.77'
5635								
5605								
5607								
5633								
5647					20.75'			
5609								
5611								
5645								
5613								
5643								
5641								
5631								
5615								20.75'

GARAGES

WILSON, MILLER, BARTON & PEEK, INC.
 ENGINEERS - SURVEYORS - PLANNERS - ARCHITECTS - CONSULTANTS
 133 S. MACINTOSH ROAD
 SARASOTA, FLORIDA 34232
 PROJECT NUMBER 2349-16
 WORK ORDER NUMBER: 5615

ARTICLES OF INCORPORATION
OF
ASHTON LAKES NO. 9 CONDOMINIUM ASSOCIATION, INC.

The undersigned by these Articles associate themselves for the purpose of forming a corporation not for profit under Chapter 617, Florida Statutes, and certify as follows:

ARTICLE 1
Name and Definitions

1.1) Name. The name of the corporation shall be ASHTON LAKES NO. 9 CONDOMINIUM ASSOCIATION, INC., a Florida corporation not for profit. For convenience, the corporation shall be herein referred to as the "Association". The principal place of business is 2951 Clark Road, Sarasota, Florida 34231.

1.2) Address and Registered Agent. The street address of the initial registered office of the Association is 1605 Main Street, Suite 1111, Sarasota, FL 34236, and the name of the Association's initial registered agent is R. Craig Harrison.

ARTICLE 2
Purpose

2.1) Purpose. The purpose for which the Association is organized is to provide an entity pursuant to Florida Statutes 718.111 of the Condominium Act for the maintenance, operation and management of Ashton Lakes No. 9 Condominium Association, Inc. (herein referred to as the "Condominium") located in Sarasota County, Florida.

2.2) Distribution of Income. The Association shall make no distribution of income to and no dividend shall be paid to its members, directors, or officers.

2.3) No Shares of Stock. The Association shall have no shares of stock.

ARTICLE 3
Powers

3.1) Common Law and Statutory Powers. The Association shall have all of the common law and statutory powers of a corporation not for profit and all of the powers and duties of an Association as set forth in Section 718.111, Florida Statutes, and those set forth in the Declaration of Condominium and the Association Bylaws if not inconsistent with the Florida Condominium Act.

3.2) Specific Powers. The Association shall have all of the powers and duties set forth in the Condominium Act of the State of Florida and conferred by the Declaration, including all of the powers and duties reasonably necessary to maintain, manage, and operation the Condominium pursuant to such Declaration of Condominium and as it may be amended from time to time, including

FILED
1994 NOV 10 AM 8:26
SECRETARY OF STATE
TALLAHASSEE, FLORIDA

** OFFICIAL RECORDS **
BOOK 2740 PAGE 1118

but not limited to the following:

- (a) To make and collect assessments against members as Unit Owners to defray the costs, expenses and losses of the Condominium.
- (b) To use the proceeds of assessments in the exercise of its powers and duties.
- (c) To maintain, repair, replace and operate the Condominium property.
- (d) To purchase insurance upon the Condominium property and insurance for the protection of the Association and its members as Unit Owners.
- (e) To make and amend from time to time reasonable rules and regulations respecting the use of the property within the Condominium.
- (f) To approve or disapprove the sale, transfer, lease, mortgage, occupation and ownership of Units in the Condominium.
- (g) To enforce by legal means the provisions of the Condominium Act of the State of Florida, the Declaration of Condominium, these Articles of Incorporation, Bylaws of the Association, and the regulations for use of the property of the Condominium.
- (h) To contract for the management and maintenance of the Condominium and to authorize a management agent to assist the Association in carrying out its powers and duties by performing such functions as the collection of Assessments, preparation of records, enforcement of rules, and maintenance of the common elements. The Association shall, however, retain at all times the powers and duties granted them by the Condominium Act, including, but not limited to, the making of assessments, promulgation of rules, execution of contracts on behalf of the Association.
- (i) To contract for the management or operation of portions of the common elements susceptible to separate management or operation, and to lease such portions.
- (j) To employ personnel to perform the services required for proper operation of the Condominium.
- (k) To acquire or enter into (prior or subsequent to the recording of the Declaration of Condominium), agreements whereby it acquires leaseholds,

memberships or other possessory or use interests in real and personal property, including, but not limited to, country clubs, golf courses, marinas, and other recreational facilities, whether or not contiguous to the lands of the Condominium, intended to provide for the enjoyment, recreation or other use or benefit of the Unit Owners, to declare expenses in connection therewith to be common expenses, and to adopt covenants and restrictions relating to the use thereof.

(1) To borrow money with following limitations: The Association shall have the right to borrow money upon the approval by the Board of Administrators alone up to an amount which is Twenty (20%) percent of the annual budget, cumulatively in a budget year. However, if the amount of same shall exceed Twenty (20%) percent of the annual budget, cumulatively in a budget year, then the loan may not be made unless ratified by a majority of the voting interests of all members of the Association.

3.3) Assets Held in Trust. All funds and properties acquired by the Association and the proceeds thereof shall be held in trust for the members in accordance with the provisions of the Declaration of Condominium, these Articles of Incorporation, and the Bylaws of the Association.

3.4) Limitation On Exercise of Powers. The powers of the Association shall be subject to and shall be exercised in accordance with the provisions of the Declaration of Condominium and the Bylaws of the Association.

ARTICLE 4 Members

4.1) The members of the Association shall consist of all of the record Owners of Units in the Condominium from time to time, and after termination of the Condominium shall consist of those who are members at the time of such termination and their successors and assigns.

4.2) Change of Membership. After receiving any approval of the Association required by the Declaration of Condominium, change of membership in the Association shall be established by the recording in the Public Records of Sarasota County, Florida, of a deed or other instrument establishing a change of record title to a Unit in the Condominium and the delivery to the Association of a certified copy of such instrument. The Owner designated by the instrument thereby automatically becomes a member of the Association and membership of the prior owner is terminated.

4.3) Limitation on Transfer of Shares of Assets. The share of a member in the funds and assets of the Association cannot be

assigned, hypothecated or transferred in any manner, except as an appurtenance to the members' Unit.

4.4) Voting. Each Unit shall be entitled to one vote. The exact number of votes to be cast by Owners of a Unit and the manner of exercising voting rights shall be determined by the Bylaws of the Association.

ARTICLE 5
Administrators

5.1) Board of Administrators and Election of Administrators. The affairs of the Association shall be managed by a Board of Administration consisting of three (3) Administrators. Administrators, other than those elected or appointed by Developer, must be members of the Association. The Administrators of the Association shall be elected at the annual meeting of the members in the manner determined by the Bylaws of the Association. Vacancies on the Board of Administrators shall be filled in the manner provided by the Bylaws of the Association and Administrators may be removed as provided for in the Condominium Act.

5.2) First Board of Administrators. The names and addresses of the members of the first Board of Administrators who shall hold office until their successors are elected and have qualified, or until removed, are as follows:

<u>Name</u>	<u>Address</u>
Alan C. Roberts	2951 Clark Road Sarasota, FL 34231
Laura Roberts	2951 Clark Road Sarasota, FL 34231
R. Craig Harrison	1605 Main St., Suite 1111 Sarasota, FL 34236

The administrators shall exercise all the duties and powers of the Association as provided by the common law and statutory powers of a corporation not for profit under the laws of the State of Florida, the Condominium Act, Declaration of Condominium, these Articles and the Bylaws.

ARTICLE 6
Officers

6.1) The affairs of the Association shall be administered by a President, one (1) or more Vice Presidents, a Secretary and a Treasurer and such other officers as may be designated in the Bylaws of the Association. The officers shall be elected by the board of directors at its annual meeting which shall immediately follow the annual meeting of the members of the corporation and shall serve at the pleasure of the board of directors. The names and address of the officers who shall serve until their

successors are designated by the board of directors are as follows:

Name	Office	Address
Alan C. Roberts	President	2951 Clark Rd. Sarasota, FL 34231
Laura Roberts	Vice President/ Treasurer	2951 Clark Road Sarasota, FL 34231
R. Craig Harrison	Secretary	1605 Main St., #1111 Sarasota, FL 34236

ARTICLE 7
Indemnification

7.1) Indemnification. The Association does indemnify any officer, Administrator, committee member, employee and agent who was or is a party in any proceedings (other than action by or in the right of the Association against such person), by reason of the fact that such person is or was an Administrator, officer, committee member, employee or agent of the Association, or is or was serving at the request of the Association as an Administrator, officer, committee member, employee or agent of another corporation, partnership, joint venture, trust or other enterprise against liability incurred in connection with such proceedings in accordance with and subject to the limitation of Florida Statute 607.014 as amended from time to time.

7.2) Exculpation. This Association has been formed by officers, Administrators and/or nominees of the Developer named within the Articles of Incorporation. No contract or other transaction between this Association and the Developer or any other person or corporation shall be void or voidable because the Developer or its officers, Administrators, and/or nominees are financially interest in either this Association or are so interested in the other party to the contract or the transaction or both.

ARTICLE 9
Bylaws

8.1) The Bylaws of the Association may be altered, amended or repealed by the members in the manner provided by the Bylaws.

ARTICLE 9
Amendments

9.1) Amendments. Amendments to these Articles of Incorporation shall be adopted in the following manner:

- (a) Notice of the subject matter of a proposed amendment shall be included in the notice of any meeting at which a proposed amendment is considered.

(b) A resolution for the adoption of a proposed amendment may be proposed either by the Board of Administrators or by a majority of the members of the Association.

(c) Approval of Amendments to the Articles of Incorporation must be by at least 51% of the members of the Association.

9.2) Limitation on Amendments. No amendment shall make any changes in the qualification for membership, the voting rights of members, nor any change in Section 2.1, 2.2, or 2.3 of Article 2, Section 3.3 of Article 3, or Section 10.1 of Article 10, without approval in writing by all members and the joiner of all record owners of mortgages upon the condominium units.

9.3) A copy of each amendment to these Articles shall be filed with the Office of the Secretary of State as required for Articles of Incorporation and shall be recorded in the Public Records of Sarasota County, Florida.

ARTICLE 10

Term

10.1) Term. The term of the Association shall be perpetual.

ARTICLE II

Subscribers (Incorporators)

11.1) Names and Addresses. The names and residence addresses of the subscribers (incorporators) of these Articles of Incorporation are as follows:

Laura Roberts

2951 Clark Road
Sarasota, FL 34231

IN WITNESS WHEREOF the subscribers have affixed their signatures this 7th day of November, 1994.

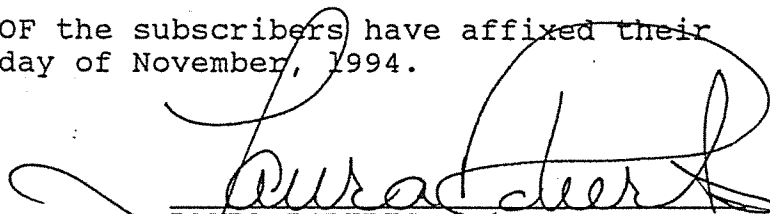
LAURA ROBERTS

STATE OF FLORIDA
COUNTY OF SARASOTA

I HEREBY CERTIFY that on this 7th day of November, 1994, before me, an officer duly qualified to take acknowledgments, on oath personally appeared LAURA ROBERTS, who is personally known to me, who executed the foregoing instrument and acknowledged before me that she executed the same.

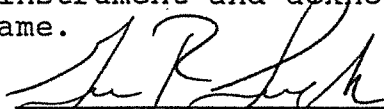

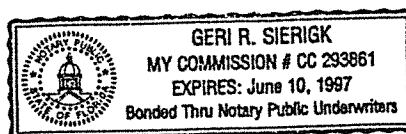
Notary Public Geri R. Sierigk
My commission expires:



CERTIFICATE DESIGNATING PLACE OF BUSINESS OR DOMICILE
FOR THE SERVICE OF PROCESS WITHIN THIS STATE,
NAMING AGENT UPON WHOM PROCESS MAY BE SERVED

In pursuance of Florida Statutes, the following is submitted in compliance with said Statute:

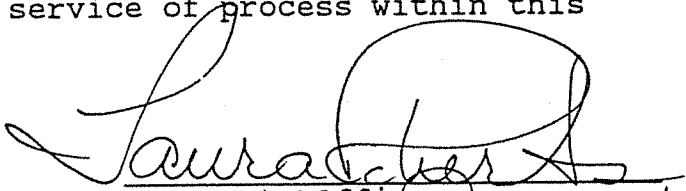
That ASHTON LAKES NO. 9 CONDOMINIUM ASSOCIATION, INC., desiring to organize under the laws of the State of Florida with its principal office, as indicated in the Articles of Incorporation in the County of Sarasota, State of Florida, has named R. CRAIG HARRISON, located at 1605 Main St., Suite 1111, Sarasota, Florida 34236 as its agent to accept service of process within this State.

Corporate Officer
Title: Vice-President
Date: Nov 7, 1994

ACKNOWLEDGMENT

Having been named to accept service of process for the above stated corporation, the place designated in this certificate, I hereby accept to act in this capacity, and agree to comply with the provisions of said Statute relative to keeping open said office.

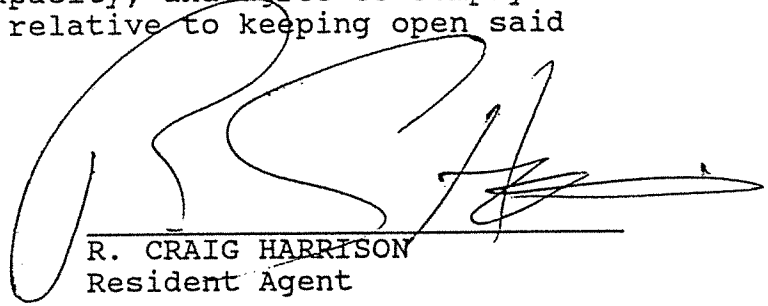
R. CRAIG HARRISON
Resident Agent
Date: Nov 7, 1994

FILED
1994 NOV 10 AM 8:27
SECRETARY OF STATE
TALLAHASSEE, FLORIDA

BYLAWS

OF

ASHTON LAKES NO. 9 CONDOMINIUM ASSOCIATION, INC.

A corporation not for profit
under the laws of the State of Florida

1. Identity. These are the Bylaws of ASHTON LAKES NO. 9 CONDOMINIUM ASSOCIATION, INC., a corporation not for profit under the laws of the State of Florida (herein called the "Association"), the Articles of Incorporation of which were filed in the office of the Secretary of State of the State of Florida on November 10, 1994. The Association has been organized pursuant to Section 718.111 of the Condominium Act for the maintenance, operation and management of ASHTON LAKES NO. 9, a Condominium (herein called the "Condominium", located in the County of Sarasota, Florida.

1.1 The office of the Association shall be at 2951 Clark Road, Sarasota, Florida 34231.

1.2 The fiscal year of the Association shall end on December 31 of each year.

1.3 The seal of the corporation shall bear the name of the corporation, the word "Florida", the words "Corporation not for profit" and the year of incorporation, an impression of which is as follows:

1.4 As used herein, "Association" means the corporation named within the title to these Bylaws; "Corporate" refers to the within named "Association"; "Member or Members" means the owner or owners of units within the Condominium but as respects voting means only the person entitled to cast the vote attributable to Unit ownership; "Board of Administration or Administrator" means that or those of this Association; "Declaration" means the Declaration of Condominium of this Condominium; "Articles of Incorporation" means of the within named Association.

1.5 Except as otherwise provided within the documents, if there is a conflict among the provisions of the following documents, the provisions of the documents shall prevail in the following order: Declaration, Articles of Incorporation, these Bylaws, and Rules and Regulations promulgated and adopted by the Board of Administration.

2. Member's meetings.

2.1 The annual members' meeting shall be held at a time and place to be designated by the Board of Administrators during the months of January and February of each year for the purpose of electing

administrators and conducting such business as is authorized to be transacted by the members. The members shall meet at least once in each calendar year. However, no annual meeting of the membership shall be held until the time specified within the Articles of Incorporation of this Association.

2.2 Special members' meetings shall be held whenever called by the President or Vice President or by a majority of the Board of Directors, and must be called by such officers upon receipt of a written request from members entitled to cast two-thirds (2/3rds) of the votes of the entire membership. A special meeting of the Unit Owners to recall a member or members of the Board or to consider the budget if the assessment exceeds the previous year by 115% may be called by ten percent (10%) of the Unit Owners giving notice of the meeting as required for a meeting of Unit Owners, which notice must state the purpose of the meeting.

2.3 Notice of all members' meetings stating the time and place and the purpose for which the meeting is called shall be given by the President or Vice President or Secretary unless waived in writing. Such notice shall be in writing to each member at his address as it appears on the books of the Association and shall be mailed not less than fourteen (14) days nor more than sixty (60) days prior to the date of the meeting. Proof of such mailing shall be given by the affidavit of the person giving the notice or United States Postal Service Certificate of Mailing. In addition, a notice of each meeting of the members shall be posted at a conspicuous place on the Condominium property at least fourteen (14) continuous days prior to each meeting of the members. Upon notice to owners, the Board shall designate a specific location on the Condominium property upon which all notices of Unit Owner meetings shall be posted. The notice of the annual meeting of the members must be sent by mail to each Unit Owner and the post office certificate retained as proof of such mailing unless the particular Unit Owner has waived in writing the right to receive the notice of the annual meeting by mail. Where a Unit is owned by more than one person, the Association shall provide notice, for meetings and all other purposes, to that one address which the Developer initially identifies for that purpose and thereafter as one or more of the owners of the Unit shall so advise the Association in writing, or if no address is given or the owners of the Unit do not agree, to the address provided on the deed of record. If a Unit is transferred after the notice is given by the Association, the transferee need not be notified. Attendance at any meeting, annual or special, by a member constitutes a waiver of notice unless at the beginning of the meeting he objects to it because it is not legally called. Notice may be waived before, at or after a meeting, whether annual or special, and Unit Owners may take action by written agreement without meetings if allowed by these Bylaws, the Declaration of Condominium, or any Florida Statute.

2.4 The record date on which members who were entitled to notice of a meeting are determined is three (3) days prior to date the first notices are mailed or hand delivered.

2.5 A quorum at members' meetings shall consist of the owners of a majority of the units of the entire condominium. All decisions at a members' meeting shall be made by a majority of the units represented at a meeting at which a quorum is present, except when approval by a greater number of members is required by the Declaration of Condominium, the Articles of Incorporation or these Bylaws. If a quorum is established, the subsequent withdrawal of members that reduces the number below that originally required for determination of quorum shall not affect the validity of any action thereafter taken at the meeting or any adjournment of it.

2.6 Voting.

a. In any meeting of members the owners of units in the condominium shall be entitled to cast one vote for each Unit, unless the decision to be made is elsewhere required to be determined in another manner.

b. If a Unit is owned by one person, his right to vote shall be established by the record title to his Unit. If a Unit is owned by more than one person, only one of the record owners shall cast the vote for the Unit and it may be presumed by the Association that the person purporting to cast the vote for a particular Unit is authorized by the owners of the Unit to cast that vote. In the event of a dispute among the owners of a Unit as to the person entitled to cast the vote of that Unit, no owner shall be able to cast the vote of that Unit until such time as the dispute is resolved and the Unit Owners of record have filed with the Association a certificate in writing, designating the person to cast the vote for the Unit, which certificate must be signed by at least a majority of owners of record of the particular Unit. If a Unit is owned by a corporation, the person entitled to cast the vote for the Unit (who shall be one of the current officers or directors of the corporation) shall be designated by a certificate signed by a corporate officer and filed with the Association at or prior to the particular meeting. Such certificates shall be valid until revoked or until superseded by a subsequent certificate or until a change in the ownership of the Unit concerned. A certificate designating the person entitled to cast the vote of a corporation or an agreement in writing settling a dispute as to the person entitled to cast the vote for the Unit owned by more than one may be amended or revoked from time to time. Such amendment or revocation by a corporation shall be signed by any person authorized to act for the corporation and an amendment or revocation settling a dispute shall be executed by a majority of the Unit Owners. If the certificate to be filed by a corporation or an agreement in writing to settle a dispute among owners of a Unit is not on file, the vote of such Unit and the Owners thereof shall not be considered in determining the requirement for a quorum or any other purpose.

2.7 Proxies. Except as specifically otherwise provided herein, the use of general and limited proxies shall be governed by Section 718.112, Florida Statutes, as amended from time to time. Any

person who has attained the age of 18 years may be named a proxy. A person named as a proxy need not be a Unit Owner. A proxy may be made by any person entitled to vote and shall be effective only for the specific meeting for which originally given and any lawfully adjourned meetings thereof. In no event shall any proxy be valid for a period longer than ninety (90) days after the date of the first meeting for which it was given. Every proxy shall be revocable at any time at the pleasure of the Unit Owner executing it. Each proxy shall specifically set forth the name of the person voting by proxy, and the name of the person authorized to vote the proxy for him. Each proxy shall contain the date, time and place of the meeting for which the proxy is given, and if a limited proxy, shall set forth those items which the holder of the proxy may vote, and the manner in which the vote is cast.

2.8 Adjourned meetings. If any meeting of members cannot be organized because a quorum has not attended, the members who are present, either in person or by proxy, may adjourn the meeting from time to time until a quorum is present.

2.9 The order of business at annual members' meetings and as far as practical at other members' meetings, shall be:

- a. Election of chairman of the meeting
- b. Calling of the roll and certifying of proxies
- c. Proof of notice of meeting or waiver of notice
- d. Reading and disposal of any unapproved minutes
- e. Reports of officers
- f. Reports of committees
- g. Election of inspectors of election
- h. Election of directors
- i. Unfinished business
- j. New business
- k. Adjournment

2.10 Waiver of Notice. The members may waive notice of any specific members' meeting in writing or orally before or after any meeting. The members may also act by written agreement without meeting.

2.11 Deleted.

2.12 Minutes. Minutes of each annual and any special members' meeting shall be kept in a businesslike manner by the Secretary of the Association and shall be available for inspection by Unit Owners and members of the Board of Administration at all reasonable times upon reasonable advance notice to the Secretary.

3. Board of Administration: Members and Duties.

3.1 Board of Administration. The affairs of the Association shall be managed by the Board of Administrators.

3.2 Membership. The Board of Administrators shall consist of

three administrators elected for staggered three (3) year terms. The first three Administrators elected after Developer control shall be elected for terms of one, two and three years.

3.3 Qualifications. All administrators shall be Unit Owners, co-owners or officers of corporate owners and be at least eighteen (18) years of age, except those Administrators elected or appointed by the Developer pursuant to Article 5.1 of the Articles of Incorporation.

3.4 Election of Administrators shall be conducted in the following manner:

a. Prior to the annual meeting prescribed in Article 5.1 of the Articles of Incorporation, administrators shall be chosen as prescribed in the Articles of Incorporation.

b. Subsequent to the first Board of Administrators prescribed in Article 5.2 of the Articles of Incorporation, the administrators shall be chosen at the annual meeting of members by a plurality of the votes cast at the election and shall hold office until the next annual meeting of members or the election and qualification of their successors or until the administrators earlier resignation, removal or death. Administrators may be removed with or without cause by the vote or agreement in writing of a majority of all Unit Owners.

c. Not less than sixty (60) days before a scheduled election, the Association shall mail or deliver, whether by separate Association mailing or included in another Association mailing or delivery including regularly published newsletters, to each Unit Owner entitled to vote, a first notice of the date of the election. Any Unit Owner or other eligible person desiring to be a candidate for the Board of Administration must give written notice to the Association not less than forty (40) days before a scheduled election. The Board shall hold a meeting within five (5) days after the deadline for a candidate to provide notice to the Association of intent to run. At this meeting, the Board shall accept additional nominations. Any Unit Owner or other eligible person may nominate himself or may nominate another Unit Owner or eligible person, if he has permission in writing to nominate the other person.

d. Not less than thirty (30) days before the election, the Association shall mail or deliver a second notice of the election to all owners entitled to vote therein, together with a ballot which shall list all candidates. Upon request of a candidate, the Association shall include an informational sheet, no larger than eight and one-half inches by eleven inches (8 1/2 x 11), which must be furnished by the candidate not less than thirty-five (35) days before the election, to be included with the mailing of the ballot, with the cost of mailing and copying to be borne by the Association. The original copy of the informational sheet shall become part of the official records of the Association.

e. The election shall be by a ballot and by a plurality of the votes cast, each person voting being entitled to cast his vote for each of as many nominees as there are vacancies to be filled. There shall be no cumulative voting. Proxies shall in no event be used in electing the Board of Administration, either in general elections or elections to fill vacancies caused by recall, resignation, or otherwise. There shall be no quorum requirement; however, at least twenty percent (20%) of the eligible voters must cast a ballot in order to have a valid election of members of the Board of Administration. If two or more candidates for the same position receive the same number of votes, which would result in one or more candidates not serving or serving a lesser period of time, the Association shall conduct a run-off election in accordance with the following. Within seven (7) days of the date of the election at which the tie vote occurred, the Board shall mail or personally deliver to the voters, a notice of a run-off election. The only candidates eligible for the run-off election to the Board position are the run-off candidates who received the tie vote at the previous election. The notice shall inform the voters of the date scheduled for the run-off election to occur, shall include a proper ballot and shall include copies of any candidate information sheets previously submitted by those candidates to the Association. The run-off election must be held not less than twenty-one (21) days, nor more than thirty (30) days, after the date of the election at which the tie vote occurred.

f. Except as to vacancies provided by removal of administrators by members, vacancies in the Board of Administrators occurring between annual meetings of members shall be filled by the affirmative vote of the majority of the remaining administrators, even if the remaining administrators constitute less than a quorum or by the sole remaining administrator.

g. Subject to the provisions of §718.301, Florida Statutes, any administrator may be removed with or without cause in accordance with §718.112, Florida Statutes, as amended from time to time.

h. An election and balloting shall not be required unless more candidates file notice of intent to run or are nominated than vacancies exist on the Board.

3.5 The organization meeting of a newly-elected Board of Administrators shall be held within ten (10) days of their election at such place and time as shall be fixed by the administrators at the meeting at which they were elected.

3.6 Regular meetings of the Board of Administrators may be held at such time and place as shall be determined, from time to time, by a majority of the administrators. Notice of regular meetings (except for any such meeting at which the adoption of the annual budget is to be considered) shall be given to each administrator, personally or by mail, telephone or telegraph, at least three (3) days prior to the day named for such meeting.

3.7 Special meetings of the administrators may be called by the President and must be called by the Secretary at the written request of one-third (1/3) of the administrators. Notice of special meetings (except for any such meeting at which the adoption of the annual budget is to be considered and except for an emergency) shall be given personally or by mail, telephone or telegraph, at least three (3) days prior to the day named for such meeting, which notice shall state the time, place and purpose of the meeting.

3.8 Administrators' Meetings Open. All meetings of the Board of Administrators and committee thereof at which a quorum of the members of that committee is present shall be open to all Unit Owners.

3.9 Notice to Unit Owners. Notices of all meetings of the Board of Administrators "To The Attention of All Unit Owners" shall also be posted conspicuously on the Condominium property at least forty-eight (48) continuous hours in advance, except in an emergency. Notice of any meeting which non-emergency special assessments, or at which amendment to rules regarding Unit use, will be proposed, discussed, or approved, shall be in writing and mailed or delivered to the Unit Owners and posted conspicuously on the Condominium property not less than fourteen (14) days prior to the meeting. Proof of such mailing shall be given by the affidavit of the Secretary and filed among the official records of the Association. Upon notice to the Unit Owners shall by duly adopted rule designate a specific location on the Condominium property upon which all notices of Board meetings shall be posted. Notice of any meeting in which regular assessments against Unit Owners are to be considered for any reason shall specifically contain a statement that assessments will be considered and the nature of any such assessments.

3.10 Meeting to Adopt Annual Budget. The members must be given written notice of the time and place of the meeting at which the Board of Administrators will consider the annual budget. A copy of the proposed annual budget of common expenses and proposed assessments must be mailed to the members not less than thirty (30) days prior to such meeting, together with the written notice of such meeting. The meeting shall be open to the Unit Owners.

3.11 Waiver of Notice. Any administrator may waive the notice of a meeting to which he is entitled before or after the meeting and such waiver shall be deemed equivalent to the giving of notice to such administrator.

3.12 A quorum at administrators' meetings shall consist of a majority of the entire Board of Administrators. The acts approved by a majority of those present at a meeting at which a quorum is present shall constitute the acts of the Board of Administrators, except when approval by a greater number of administrators is required by the Condominium Act, the Declaration of Condominium, the Articles of Incorporation or these Bylaws. When some or all of the Board members meet by telephone conference, those Board members attending by telephone conference may be counted toward obtaining a quorum and may vote by

telephone. A telephone speaker shall be utilized so that the conversation of those Board members attending by telephone may be heard by the Board members attending in person, as well as by any unit owners present at a meeting.

3.13 Adjourned Meetings. If at any meeting of the Board of Administrators there be less than a quorum present, the majority of those present may adjourn the meeting from time to time until a quorum is present. At any adjourned meeting any business that might have been transacted at the meeting as originally called may be transacted.

3.14 Joinder in Meeting by Approval of Minutes. A member of the Board of Administration may join by written concurrence in any action taken at a meeting of the Board but such concurrence may not be used for the purposes of creating a quorum.

3.15 The presiding officer of administrators' meetings shall be the Chairman of the Board, if such an officer has been elected; and if none, the President shall preside. In the absence of the presiding officer the administrators present shall designate one of their number to preside.

3.16 The order of business at administrators' meetings shall be:

- a. Calling of roll
- b. Proof of due notice of meeting
- c. Reading and disposal of any unapproved minutes
- d. Reports of officers and committees
- e. Election of officers
- f. Unfinished business
- g. New business
- h. Adjournment

3.17 Administrators' compensation, if any, shall be determined by the members.

3.18 Committees. The Board of Administrators by resolution adopted by a majority of the full Board may designate from among its members an executive committee, and one or more other committees, whose exercise of power shall be subject to the prior and subsequent approval of the Board of Administrators. The Board of Administrators may delegate to the executive committee such powers as it deems proper, except as prohibited by Florida Statutes, §607.0825 (a-e) and the Board may designate one or more members as alternate members of any such committee who may act in the place and stead of any absent member or members at any meeting of such committee.

3.19 Regulations. The Board of Administrators may adopt, amend and rescind Rules and Regulations to govern the operation and use of the Condominium, its property, the common elements and any lease, recreational or other common facility. The Rules and Regulations shall

be uniform and shall not conflict with the Declaration, Articles of Incorporation or these Bylaws.

4. Powers and Duties of the Board of Administrators. All of the powers and duties of the Association existing under the Condominium Act, the Declaration of Condominium, Articles of Incorporation and these Bylaws shall be exercised exclusively by the Board of Administrators, its agents, contractors or employees subject only to approval by Unit Owners when such is specifically required. The Association shall have all of the powers and duties set forth in the Condominium Act (Chapter 718 F.S.) and all of the powers and duties reasonably necessary to operate the Condominium pursuant to the Declaration and as it may be amended from time to time, including but not limited to the powers as set forth in the Articles of Incorporation.

5. Officers.

5.1 The executive officers of the Association shall be a President, who shall be the administrator, a Vice President, who shall be an administrator, a Treasurer, a Secretary and an Assistant Secretary, all of whom shall be elected annually by the Board of Administrators and shall serve at the pleasure of the Board of Administrators. Any person may hold two or more offices, except that the President shall not be also the Secretary or an Assistant Secretary. The Board of Administrators from time to time shall elect such other officers and designate their powers and duties as the Board shall find to be required to manage the affairs of the Association.

The Board of Administrators shall elect a delegate and alternate to the Board of Administrators of ASHTON LAKES COMMUNITY ASSOCIATION, who shall serve for a two (2) year term. Such persons shall be members of the Board of Administration of the Condominium and may hold that office in addition to any other office of the Association.

5.2 The President shall be the chief executive officer of the Association, and shall be an ex officio member of all such standing committees except any nominating committee. He shall have all of the powers and duties usually vested in the office of President of an Association, including but not limited to the power to appoint committees from among the members from time to time, as he in his discretion may determine appropriate, to assist in the conduct of the affairs of the Association.

5.3 The Vice President in the absence or disability of the President shall exercise the powers and perform the duties of the President. He also shall assist the President generally and exercise such other powers and perform such other duties as shall be prescribed by the Administrators.

5.4 The Secretary shall keep the minutes of all proceedings of the administrators and the members. He shall attend to the giving

and serving of all notices to the members and administrators and other notices required by law. He shall have custody of the seal of the Association and affix it to instruments requiring a seal when duly signed. He shall keep the records of the Association, except those of the Treasurer, and shall perform all other duties incident to the office of Secretary of an association and as may be required by the Administrators or the President. The Assistant Secretary shall perform the duties of the Secretary when the Secretary is absent.

5.5 The Treasurer shall have custody of all property of the Association, including funds, securities and evidences of indebtedness. He shall keep the books of the Association in accordance with good accounting practices; and he shall perform all other duties incident to the office of Treasurer.

5.6 The compensation, if any, of all officers and the compensation of all employees of the Association shall be fixed by the Administrators. The provision that Administrators' fees shall be determined by members shall not preclude the Board of Administrators from employing an Administrator as an employee of the Association, nor preclude the contracting with an Administrator Director for the management of the Condominium.

5.7 All officers serve at the pleasure of the Board of Administrators. Any officer may be removed by a majority vote of the Administrators at a special meeting called for that purpose.

5.8 A vacancy in office shall be filled by the Board of Administrators as soon as is practicable following the creation of the vacancy.

6. Fiscal Management. The provisions for fiscal management of the Association set forth in the Declaration of Condominium and Articles of Incorporation shall be supplemented by the following provisions:

6.1 Accounts. The receipt and expenditures of the Association shall be credited and charged to accounts under the following classifications as shall be appropriate, all of which expenditures shall be common expenses:

a. Current expense, which shall include an amount no less than is required to provide funds in advance for payment of all of the anticipated current operating expense and for all of the unpaid operating expense previously incurred.

b. Reserve Accounts. Reserve accounts for the funds required by the Florida Condominium Act, now Fla. Stat. 718.112(f)(2), not waived or reduced by the Unit Owners, together with money collected for capital expenditures and deferred maintenance shall be maintained by the Board of Administrators. The Board of Administrators may deposit these funds in more than one bank account but adequate accounting records shall be kept so that the funds will be used only for the

purpose designated. The reserves shall only be used for the purpose for which they are reserved unless their use for other purposes is approved in advance by vote of the majority of the voting interests of the Association present at a duly called meeting of the Association.

Each reserve account shall be stated as a separate item and the budget shall show the estimated life, estimated replacement cost, and the estimated remaining useful life for each item for which reserves are maintained or required, if not waived. The budget shall state separately the current balance in each reserve account as of the date the proposed budget is prepared.

Reserves shall be established and maintained for capital expenditures and deferred maintenance (purchase or replacement of an asset whose life is greater than one year or the addition of an asset which extends the life of a previously existing asset for a period greater than one year).

6.2 Annual Budget. The proposed annual budget of common expenses of the condominium shall be detailed and shall show the amount that is required to provide funds in advance for payment of all of the anticipated current operating expenses and for all of the unpaid operating expenses previously incurred. Expenses shall be shown monthly and annually. The budget shall state accounts and expense classifications including, but not limited to:

Expenses for ASHTON LAKES NO. 9 CONDOMINIUM ASSOCIATION, INC.:

- (1) Administrative and salary expenses;
- (2) Management fees;
- (3) Professional fees and expenses;
- (4) Costs for building maintenance and repair;
- (5) Expenses for refuse collection and utility services;
- (6) Insurance;
- (7) Security provisions;
- (8) Other expenses;
- (9) Operating capital;
- (10) General reserves, maintenance reserves and depreciation reserves;
- (11) Fees paid Bureau of Condominiums, Division of Florida Land Sales and Condominiums.

Expenses for an Owner of a Unit in ASHTON LAKES NO. 9, a Condominium:

- (1) The payment due ASHTON LAKES COMMUNITY ASSOCIATION by its budget of anticipated expenses for the operation, maintenance, repair, and replacement of the ASHTON LAKES COMMUNITY FACILITIES for the proposed year.

a. Adoption of Budget. The Board of Administrators may adopt the proposed annual budget of common expenses for the Condominium. In such event, the Board of Administrators shall mail a notice of the meeting to adopt the proposed annual budget and copies of the proposed annual budget of common expenses to the Unit Owners not less than fourteen (14) days prior to the meeting at which the budget is to be considered.

b. Adoption of Budget by Unit Owners. As an alternative, the Board of Administrators may submit the budget to a special meeting of the Unit Owners of the Condominium and must do so when required by the provisions of Fla. Stat. 718.112(2)(e) (1993). At the special meeting of the Unit Owners to consider and enact a budget, adoption of the budget shall require a vote of not less than a majority of all the voting units in the Condominium. The budget may be proposed to the Unit Owners at a meeting of the owners or/and in writing, and if the proposed budget is approved by the Unit Owners at the meeting or by majority of the Unit Owners in writing without a meeting, the budget shall be adopted.

c. The proposed budget shall contain a statement of the reserves described above and required by the Florida Condominium Law. Such reserves shall be adopted unless waived or funded in an amount less than the total amount shown on the proposed budget at a duly called meeting of the members of the Condominium. Waiver or adoption of reserves in a lesser amount shall be by a majority vote of the members present at a duly called meeting or by a majority of all the Unit Owners of the corporation by written agreement. If reserves are not waived or funded in a lesser amount, the reserves as stated in the budget shall go into effect.

d. If the budget is amended after adoption, a copy of the amended budget shall be furnished to each member.

6.3 Assessments. The Board of Administrators shall assess the owners of Units in the Condominium for their share of the common expenses based upon the budget of the Condominium, the share of such expenses due from each Unit by the provisions of the Declaration of Condominium, and the share of the expenses of ASHTON LAKES COMMUNITY ASSOCIATION, INC. due from each Unit. Assessments shall be monthly, except when accelerated for non-payment as hereinafter provided, and shall continue until changed by the Board of Administrators. Unit Owners shall be notified each year of the annual and monthly amount of the assessment for that year. The Association is not required to send monthly statements of assessments. Payment of assessments is due from Unit Owners whether or not the notice of assessment is received.

6.4 Assessments for Emergencies. The Board of Administrators may levy an assessment for an emergency expense not set forth in the budget of the Condominium, or not set forth in the amount subsequently found to be required, without prior approval of the Unit Owners of the Condominium provided that such special assessment shall not exceed

\$500.00 per Unit. Emergency assessments shall be payable within thirty (30) days of mailing the notice of the special assessment. Unit Owners shall be given written notice of the meeting of the Board of Administrators at which the special assessment is adopted as provided by the Bylaws which shall state the amount of assessments proposed and the reasons for the assessment.

6.5 Amendments to the Annual Budget. As an alternative to emergency assessments, the annual budget of the Condominium may be amended during the budget year. Such amendment shall follow the procedure and be subject to the provisions and limitations of the Bylaws, Declaration of Condominium, and the State of Florida Condominium Act for the adoption of an annual budget.

6.6 Excess Assessments. Each year at the annual Owner's meeting or at a special meeting called for such purpose, the members shall determine whether to return to themselves any excess assessments (other than extra-ordinary assessments) not actually used in the managing, operating and maintaining of or the creation of reserves for each condominium or to have the excess applied against expenses for the following year. In the event such excess is determined to be returned to the Owners, it shall be allocated pursuant to the percentage in the common surplus held by each Unit.

6.7 Collection. A Unit Owner, regardless of how title has been acquired, including purchase at a judicial sale, is liable for all assessments which come due while he is a Unit Owner. The Unit Owner is jointly and severally liable with the grantor for all unpaid assessments against the unit for its share of the common expenses without prejudice to any rights of a grantee to recover from a grantor. The mortgagee of a first mortgage of record, or other purchaser of a unit at public sale resulting from foreclosure of a first mortgage, or the grantee of a deed given in lieu of foreclosure to a first mortgagee shall be liable for unpaid assessments for such unit that become due prior to the mortgagee's receipt of the deed. However, the mortgagee's liability is limited to a period not exceeding six (6) months, but in no event does the first mortgagee's liability exceed one percent (1%) of the original mortgage debt. The first mortgagee's liability for such expenses or assessments does not commence until thirty (30) days after the date the first mortgagee received the last payment of principal or interest. In no event shall the mortgagee be liable for more than six (6) months of the unit's unpaid common expenses or assessments accrue before the acquisition of title to the unit by the mortgagee or one percent (1%) of the original mortgage debt, whichever is less. Assessments, installments of assessments, special assessments shall bear interest from the date due at the highest rate provided by law.

a. The liability for assessments may not be waived by waiver of the use or enjoyment of any common elements or by the abandonment for which the assessment is made.

b. The Association has a lien on each condominium

parcel for any unpaid assessments with interest and for reasonable attorney's fees incurred by the association which are incident to the collection of the assessments or enforcement of the lien, which lien is subject to and may be foreclosed pursuant to the provisions of Fla. Stat. 718.116, as amended from time to time.

c. Acceleration. If the Owner(s) of a unit is in default for failure to pay an assessment, and such default continues for more than thirty (30) days after the Association gives written notice to the Unit Owner of its intention to accelerate and foreclose the lien of the Association to collect the unpaid assessments, the Association may accelerate the due date of the assessments for the balance of the year and declare all assessments for the year due and payable. The notice shall include a statement that the Association will accelerate the balance of the monthly payments of the annual assessments due from the unit, if the unpaid assessments are not paid in full, including interest, costs and attorney's fees. If the Association elects to accelerate the assessments, it must file a claim of lien and give notice of its election to accelerate in the Claim of Lien.

6.8 The depository of the Association shall be in such bank or banks as shall be designated from time to time by the Board of Administrators and in which the monies of the Association shall be deposited. Withdrawal of monies from such accounts shall be only by checks signed by such persons as are authorized by the administrators.

6.9 The Association shall provide financial statements and/or financial reports as required by Fla. Stat. 718.111(13 & 14) and the rules and regulations of the Florida Division of Land Sales and Condominiums as these may be adopted and amended from time to time.

6.10 Fidelity bonds shall be required by the Board of Administrators from all Administrators or officers handling or responsible for Association funds. The amount of such bonds shall be determined by the Administrators not less than the principal sum required by Section 718.112(2)(j), Florida Statutes, as amended from time to time. The premiums on such bonds shall be paid by the Association.

6.11 Assessment Certificate. An Owner of or mortgagee or lien holder on, any Unit within the Condominium may require the Association to furnish a certificate showing the amount of unpaid assessments against the Unit. Any person other than the Owner who relies upon the certificate shall be protected by it.

6.12 Records. The Association shall maintain accounting records for the Association for a period of seven (7) years, which records shall be kept according to good accounting practices which include but not be limited to:

a. Accurate, itemized, and detailed records of all receipts and expenditures;

b. A current account and a monthly statement of the account of each unit designating the name of the Unit Owner, the due date, and the amount of each assessment, the amount paid upon the account, and the balance due.

c. All audits, reviews, accounting statements, and financial reports of the Association or Condominium.

6.13 The Association shall maintain the following records:

a. A copy of the plans, permits, warranties, and other items provided by the Developer pursuant to Fla. Stat. 718.301(4).

b. The original or a photocopy of the recorded Declaration of Condominium and each Amendment thereto.

c. The original or a photocopy of the recorded Bylaws of the Association and each Amendment thereto.

d. A certified copy of the Articles of Incorporation of the Association and each Amendment thereto.

e. A copy of the current rules of the Association.

f. Minutes of all meetings of the Association of the Board of Administrators and of the Unit Owners, which Minutes shall be contained in books and shall be retained for a period of not less than seven years.

g. A current roster of all Unit Owners and their mailing addresses, unit numbers and, if known, telephone numbers.

h. Voting certificates of Corporations and dispute settlement agreements of Owners, when required.

i. All current insurance policies of the Association and the Condominium.

j. A copy of any management agreement, lease, or other contract to which the Association is a party, or under which the Association or the Unit Owners have an obligation and responsibility.

k. Bills of sale or transfer for all property owned by the Association.

l. Ballots, sign-in sheets, voting proxies, and all other papers relating to elections, which records shall be maintained for a period of one (1) year from the date of the meeting to which the record relates.

m. All rental records for which the Association is

acting as agent for the rental of condominium units.

n. A copy of the current question and answer sheet as described in Section 719.504, Florida Statutes.

All records shall be maintained in the County in which the Condominium is located, or within fifty (50) miles of the Condominium if maintained in another County, open to inspection by any member or his representative at reasonable times. The right to inspect includes making or obtaining copies at the member's expense.

6.14 Assessments for ASHTON LAKES COMMUNITY ASSOCIATION. ASHTON LAKES COMMUNITY ASSOCIATION shall prepare and furnish an annual budget of all proposed receipts and expenditures including reasonable allowances for contingencies and working funds. The budget of ASHTON LAKES COMMUNITY ASSOCIATION, INC. shall state the total amount to be collected from all of the Units within ASHTON LAKES Residences and the amount due from each Unit. The amount due ASHTON LAKES COMMUNITY ASSOCIATION from each Unit of ASHTON LAKES NO. 9, a Condominium, shall be included in the Annual Budget of the Condominium and collected from the individual members by the Condominium as assessments in accordance with Fla. Stat. 718.116 (1993), as amended from time to time, and the Declaration and Bylaws of the Condominium. These provisions for assessment and collection do not conflict with or modify the other provisions of the Declaration of Condominium of ASHTON LAKES NO. 9, or the Articles of Incorporation or Bylaws of ASHTON LAKES NO. 9 CONDOMINIUM ASSOCIATION, or ASHTON LAKES COMMUNITY ASSOCIATION which provides that ASHTON LAKES COMMUNITY ASSOCIATION may receive payments directly from owners and may file a lien for assessments.

Assessments to pay the amounts due by the ASHTON LAKES COMMUNITY ASSOCIATION Budget shall be divided equally among all of the owners of units in the ASHTON LAKES Community, and shall be collected by each condominium, or other organization provided to administer the residences within the ASHTON LAKES COMMUNITY.

6.15 Procedure for Levying a Fine. The procedure for levying a reasonable fine against a unit for the failure of the owner of a unit, or its occupant, licensee, or invitee, to comply with any provision of the Declaration, the Association Bylaws, or reasonable rules of the Association, shall be as follows:

a. The party against whom the fine is sought to be levied shall be afforded an opportunity for hearing after reasonable notice of not less than fourteen (14) days, which notice shall include:

(1) A statement of the date, time and place of the hearing;

(2) A statement of the provisions of the Declaration, Association Bylaws, or Association rules which have

allegedly been violated; and

(3) A short and plain statement of the matters asserted by the Association.

b. The party against whom the fine may be levied shall have an opportunity to respond, to present evidence, and to provide written and oral argument on all issues involved, and shall have an opportunity at the hearing to review, challenge, and respond to any material considered by the Association.

7. Parliamentary Rules. Roberts' Rules of Order (latest edition) shall govern the conduct of Association meetings when not in conflict with the Declaration of Condominium, Articles of Incorporation, or these Bylaws.

8. Amendments. These Bylaws may be amended in the following manner:

8.1 Notice of the subject matter of a proposed amendment shall be included in the notice of any meeting at which a proposed amendment is considered.

8.2 A resolution adopting a proposed amendment may be proposed by either the Board of Administrators of the Association or by the members of the Association. Administrators and members not present in person or by proxy at the meeting considering the amendment may express their approval in writing, providing such approval is delivered to the Secretary at or prior to the meeting. Except as elsewhere provided, such approvals must be either by:

a. not less than a majority of the votes of the entire membership of the Association; or

b. until the first election of Administrators by all of the members of the first Board of Administrators.

8.3 Proviso. Provided, however, that no amendment shall discriminate against any Unit Owner nor against any Unit or class or group of Units unless the Unit Owners so affected shall consent and no amendment shall be made that is in conflict with the Articles of Incorporation or the Declaration of Condominium. Provided that prior to giving up control of the Board of Administration, no amendment may be made to Section 6.2(A) without the written consent of the Developer of the Condominium.

8.4 Limitation on Amendments. No Bylaw shall be revised or amended by reference to its title or number only. Proposals to amend existing Bylaws shall contain the full text of the Bylaws to be amended; new words shall be inserted in the text underlined, and words to be deleted shall be lined through by a hyphen. However, if the proposed change is so extensive that this procedure would hinder rather than

assist the understanding of the proposed amendment, it is not necessary to use underlining and hyphens as indicators of words added or deleted, but instead, a notation shall be inserted immediately preceding the proposed amendment in substantially the following language: "Substantial rewording of Bylaws. See Bylaw _____ for present text." Non-material errors or omissions in the Bylaw process shall not invalidate an otherwise properly promulgated amendment.

8.5 Execution and Recording. No amendment to the Bylaws shall be valid unless set forth in or annexed to a recorded amendment to the Declaration. A copy of each amendment shall be attached to a certificate certifying that the amendment was duly adopted as an amendment to the Declaration and Bylaws, which certificate shall be executed by the appropriate officers of the Association with the formalities of a deed. The amendment shall be effective when such certificate and amendment are recorded in the Public Records of Sarasota County, Florida.

9. Minutes. Minutes of all meetings of the members and all meetings of the Board of Administrators shall be kept in a book and shall be available for inspection by Unit Owners and Board members and their authorized representatives at all reasonable times. All minutes shall be retained for a period of not less than seven (7) years.

10. Rules and Regulations. The Association may adopt reasonable rules and regulations to be uniformly applied to all members governing the details of the operation and use of the common elements. Except for the initial rules and regulations which may be adopted by the first Board of Administrators, such rules and regulations may be adopted, amended or rescinded only at any regular or special meeting of the members by a vote of at least 51% of the entire membership. The Association may conduct Bingo games as provided in §849.0931, Florida Statutes.

11. Association May Acquire and Enter Into Agreements. Subsequent to the recording of the Declaration of Condominium, the Association may acquire or enter into agreements whereby it acquires leaseholds, memberships and other possessory or use interest in real and personal property, including but not limited to, country clubs, golf courses, marinas and other recreational facilities, whether or not contiguous to the Condominium, for the enjoyment, recreation or other use or benefit of the members; and the expense of rental, membership fees, operations, replacements and other undertakings in connection therewith shall be part of the common expenses. The Board of Administrators of the Association may adopt covenants and restrictions relating to the use of such facilities.

12. Indemnification. The Association may indemnify those persons as set out within Article 7.1 of the Articles of Incorporation. The corporation shall purchase and maintain insurance against liability for all Administrators, officers, employees and agents of the corporation even if the corporation could not indemnify them under the Article 7.1

provisions or under statutory law.

13. Litigation: Notice. In any legal action in which the Association may be exposed to liability in excess of insurance coverage protecting it and the Unit Owners, the Association shall give notice of the exposure within a reasonable time to all Unit Owners and they shall have the right to intervene and defend.

14. Transfer Fee. If the transfer, lease, sale, or sublease of Units is subject to approval of anybody, no fee shall be charged in connection with a transfer, sale, or approval in excess of the expenditures reasonably required for the transfer or sale, and this expense shall not exceed 100.00. The Association may require that the prospective lessee place a security deposit, in an amount not to exceed the equivalent of one month's rent, into an escrow account maintained by the Association. The security deposit shall protect against damages to the Common Elements or Association property. No charge shall be made in connection with an extension or renewal of the lease.

15. Notice of Meeting Where Assessment to be Considered. Notice of any meeting where assessments against Unit Owners are to be considered for any reason shall specifically contain a statement that assessments will be considered and the nature of any such assessments.

16. Compliance with Applicable Fire and Safety Code. The Board of Administration may accept a Certificate of Compliance from a licensed electrical contractor or electrician as evidence of compliance of the Condominium units to the applicable fire and life safety code.

17. Arbitration. To the extent required by Chapter 718, any dispute, as that term is defined by §718.1255(1), Florida Statutes, shall be submitted to mandatory non-binding arbitration pursuant to the terms and conditions set forth in §718.1255(4), Florida Statutes.

The foregoing Bylaws were adopted as the Bylaws of ASHTON LAKES NO. 9 CONDOMINIUM ASSOCIATION, INC., a corporation not-for-profit under the laws of the State of Florida, at the first meeting of the first Board of Administrators on the 1st day of MAY, 1995.

ASHTON LAKES NO. 9 CONDOMINIUM ASSOCIATION, INC.

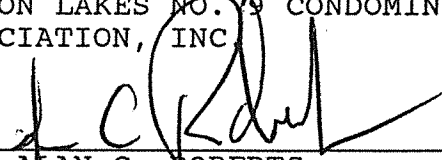
By: 
ALAN C. ROBERTS
President and Administrator

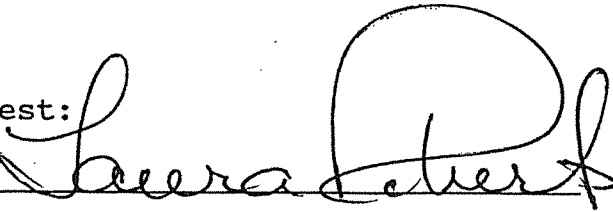
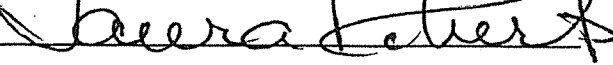
Attest: 
By: 
Secretary and Director

RECORDED IN OFFICIAL RECORDS
99 MAY 22 AM 10:14
JANEN E. RUSHING
CLERK OF CIRCUIT COURT
SARASOTA COUNTY, FL

